



Urban Planning and Architecture Design for Sustainable Development, UPADSD 14- 16 October 2015

A Design Chart to Determine the Dimensions of a Horizontal Shading Device over an Equator-Facing Window as a Function of the Latitude and the Shading Height

Shady Shawky Saifelnasr^{a*}

^aAssistant Professor, October University for Modern Sciences & Arts "MSA", Cairo, Egypt

Abstract

The main objective of this paper is to introduce a simple quick tool for architects represented by a design chart that determines the dimensions of an external horizontal shading device over an equator-facing window as a function of the latitude and the shading height, resulting in an automatic seasonal adjustment. This chart is applicable for any city all over the world at lower or middle latitudes where shading is an essential passive strategy.

© 2016 The Authors. Published by Elsevier Ltd. This is an open access article under the CC BY-NC-ND license (<http://creativecommons.org/licenses/by-nc-nd/4.0/>).

Peer-review under responsibility of IEREK, International experts for Research Enrichment and Knowledge Exchange

Keywords: Design Charts; Shading; Solar Geometry; Shading Devices

1. Introduction

External shading devices are usually more effective than internal ones and according to (Ching & Shapiro, 2014), it is very valuable to block the sun before it reaches the building. And for an equator facing façade, a horizontal shading device is effective because of the higher angles around noon that would be easily blocked with a smaller surface area. If sized correctly, a horizontal shading device could effectively block the unneeded sun within the overheated period (summer) and allow solar gains in within the underheated period (winter). So, the paper mainly concentrates on the sizing of such devices using a simple quick tool represented by a design chart that could be generic and applicable for most cities all over the world, where shading is a need.

* Shady Shawky Saifelnasr. *E-mail address:* ssaifelnasr@msa.eun.eg

Nomenclature	
HSA	horizontal shadow angle °
VSA	vertical shadow angle °
LAT	latitude °
h	shading height m
d	horizontal shading device depth m
p	protrusion of horizontal shading device exceeding the window opening length m
w	window opening length m
l	horizontal shading device total length..... m
x	spacing between horizontal shading device and wall m
y	horizontal shading device thickness m

1.1. Background and Previous Studies

This paper introduces a simple quick tool to find the dimensions of a horizontal shading device. This tool is represented by a design chart that could be considered a continuation of another design chart (made by the author in a previous research (Saifelnasr, 2013)). The first chart determines the depth of a projected structure over an equator-facing window as a function of the latitude and the shading height. The projected structure in that case is handled as a horizontal shading device which is characterized by a vertical shadow angle (VSA) and neglecting the effect of the horizontal shadow angle (HSA) assuming the uniform broadening of that projected structure along the façade. But in this paper, the design chart is developed such that it involves the integration of both shadow angles to design the required horizontal shading device and find its dimensions, as a function of the latitude and the shading height. These obtained dimensions would ensure complete summer six months sun exclusion (for an equinox cut-off) at the selected hours (cut-off times), for any location at low or middle latitudes where shading is a need.

Some previous studies as (Brown & DeKay, 2001) proposed similar charts but for a single latitude, i.e., a specific city, that finds out the depth of a single overhang or the spacing between multiple louvers as a function of the shading height. But this chart is more generic and applicable for any location (city) within the low or middle latitudes, where shading is a need during the overheated period, i.e., summer.

1.2. Main Objectives and Hypothesis

The main objective of this paper is to introduce a simple quick tool for architects represented by a design chart that integrates HSA as well as VSA to determine the dimensions of a horizontal shading device over an equator-facing window as a function of the latitude and shading height for the selected cut-off times, resulting in an automatic seasonal adjustment, i.e., full shading in summer but allowing solar heat gain in winter.

2. Methodology

To carry out the aimed design chart, a number of measuring techniques were used associated with some simplifications and assumptions as follows.

2.1. Used Measuring Techniques

Shading design for the exclusion of solar input is a geometrical task, so, the different dimensions of the horizontal shading device could be determined when all the other parameters are given represented in the shading height (h), shadow angles; (VSA) and (HSA) for the selected hours (cut-off times).

The different curves within the design chart signify the (VSA) as well as the (HSA) for the selected hours (cut-off times). Therefore, the different dimensions; depth (d) and protrusion (p) could be obtained as ratios with the shading

height (h); (d/h) and (p/h), i.e., the depth (d) and protrusion (p) of the device could be determined at the selected hours (cut-off times) as a function of the latitude (LAT) and the shading height (h).

2.2. Simplifications and Assumptions

Some experimentation parameters, simplifications and assumptions were considered in the design chart concerning its applicability, orientation of façade, effect of the thickness of the different cross sections and the specifications of the used base cases.

Applicability of the design chart: the design chart is suitable for locations found at lower latitudes with temperate, hot-dry or warm-humid climates where shading is a need, i.e. low and middle latitudes. And it is not suitable for locations found at higher latitudes with cold climates where the main problem is the lack of heat. But, for study and experimental purposes, a wider range of latitudes are considered in the design chart from 0° (equator) to 60° N and S.

Orientation: the window wall is facing the equator (due south in the northern hemisphere and due north in the southern hemisphere). The design chart is created based on the fact that a horizontal shading device above a window facing the equator, can give an automatic seasonal adjustment: full shading in summer but allowing solar heat gain in winter if the (VSA) = 90° - (LAT) (Szokolay, 2008); e.g. for the city of Cairo, Egypt ((LAT) = 30° N) it will be (VSA) = 90° - 30° = 60°.

Selected shading strategy: the horizontal shading device is considered to be fixed because shading is the main concern for such temperate and hot climates (Lechner, 2008).

Effect of the thickness of the horizontal shading device: the shaded part increases as a function of that thickness, so to avoid that effect, the shading height (h) is measured vertically from the underside of the shading device till the window sill or the ground (as in case of curtain walls).

Effect of the thickness of the external wall: the penetration of direct sunlight inside the space decreases as a function of that thickness, so to avoid that effect, the shading height (h) is measured on the external surface of the wall which implies the shading of the window sill itself, i.e., the thickness of the wall is negligible.

Specifications of the used base case:

- External length = 4.50 m
- External width = 4.50 m
- Lintel height = 2.10 m
- Window width = 1.50 m
- Sill height = 0.90 m
- Wall thickness = 0.25 m
- Slab thickness = 0.15 m
- Device thickness = 0.15 m

3. Results

Different configurations of a simple space with a horizontal shading device are introduced with different latitudes, shading heights and cut-off times. The depths (d) and protrusions (p) are identified for of all these different configurations (see Fig. 1, Fig. 2 and Fig. 3). The latitude (LAT) usually signifies the location of the city and the proposed latitudes are low, middle or high latitudes that might not be relevant to the need of shading or blocking sunrays, but mainly for study purposes; LAT 10°, LAT 20°, LAT 30°, LAT 40°, LAT 50° and LAT 60°. The shading height (h) is measured vertically from the underside of the horizontal shading device (that varies from the lintel level till the roof level) down to the sill level; 1.20 m, 1.65 m and 2.10 m. The selected hours (cut-off times) are those hours at which the sun rays are excluded from the southern façade (in the northern hemisphere) for an equinox cut-off; 0900-1500 hr, 1000-1400 hr and 1100-1300 hr.

To design the aimed chart, a formula to find (p/h) is going to be derived and then verified mathematically by comparing the values from the formula with the measured ones for the different proposed configurations.

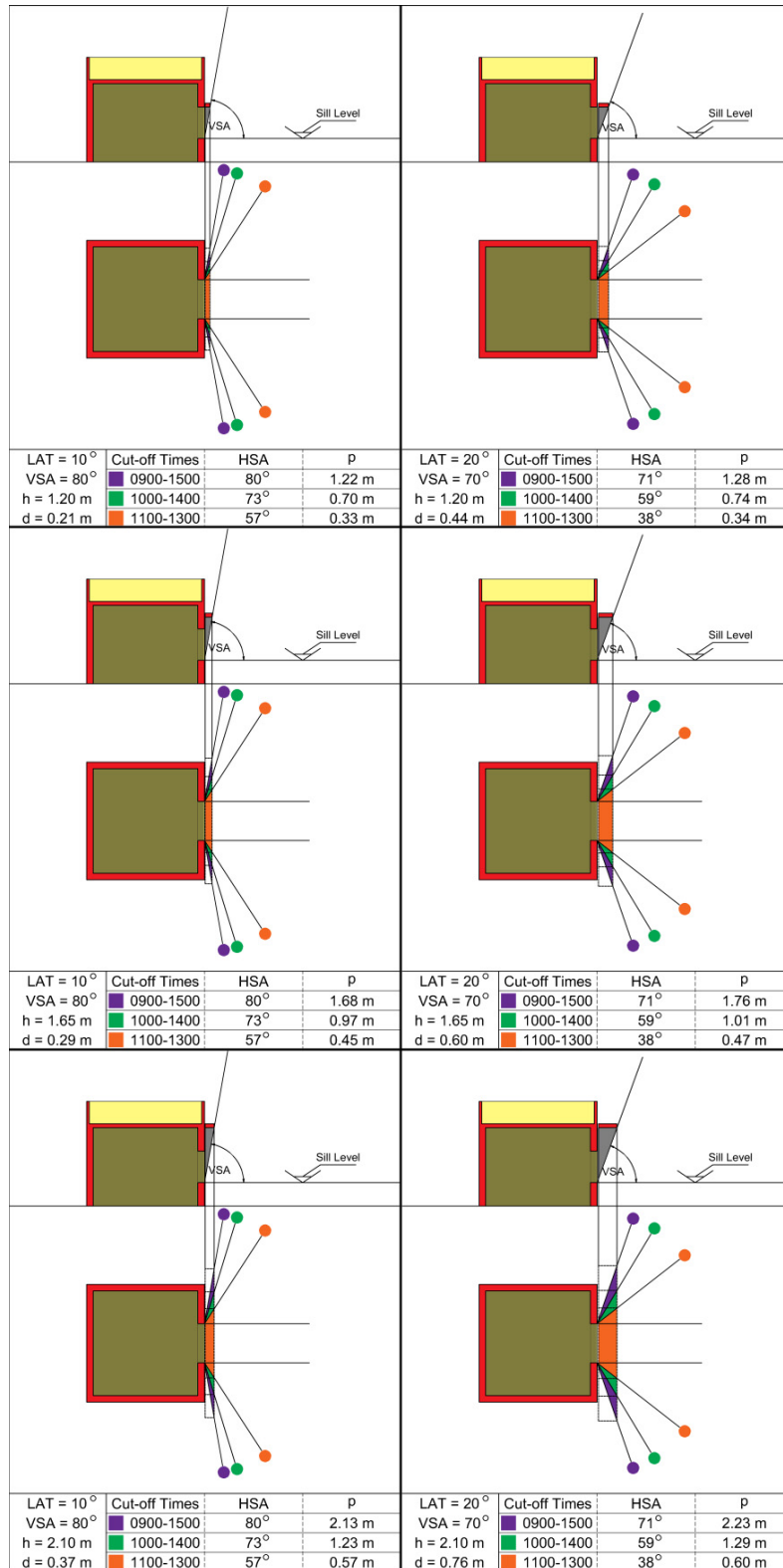

Fig. 1: Different configurations of horizontal shading devices with different shading heights (h) for Latitude 10° and 20°.

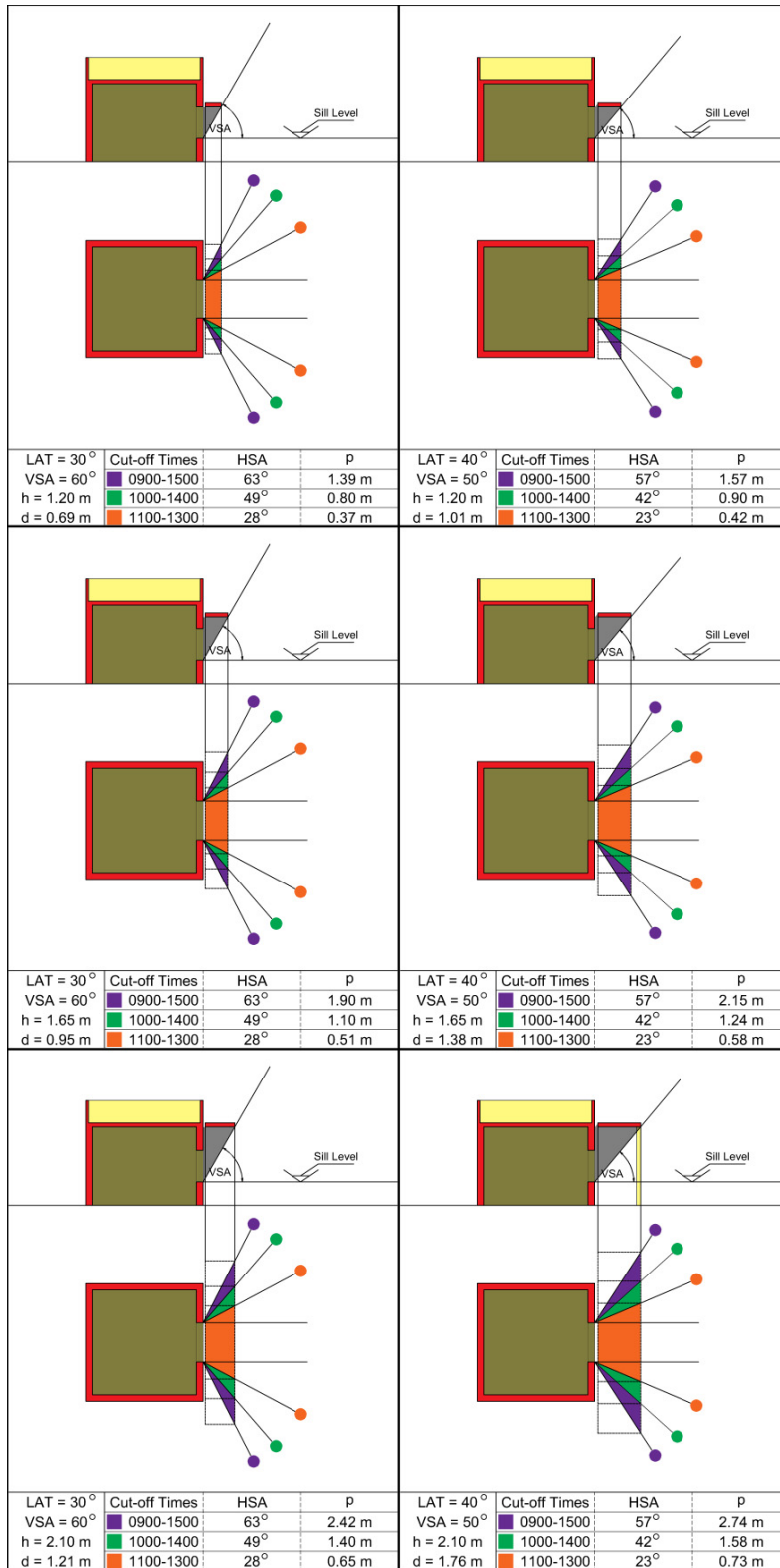

Fig. 2: Different configurations of horizontal shading devices with different shading heights (h) for Latitude 30° and 40°.

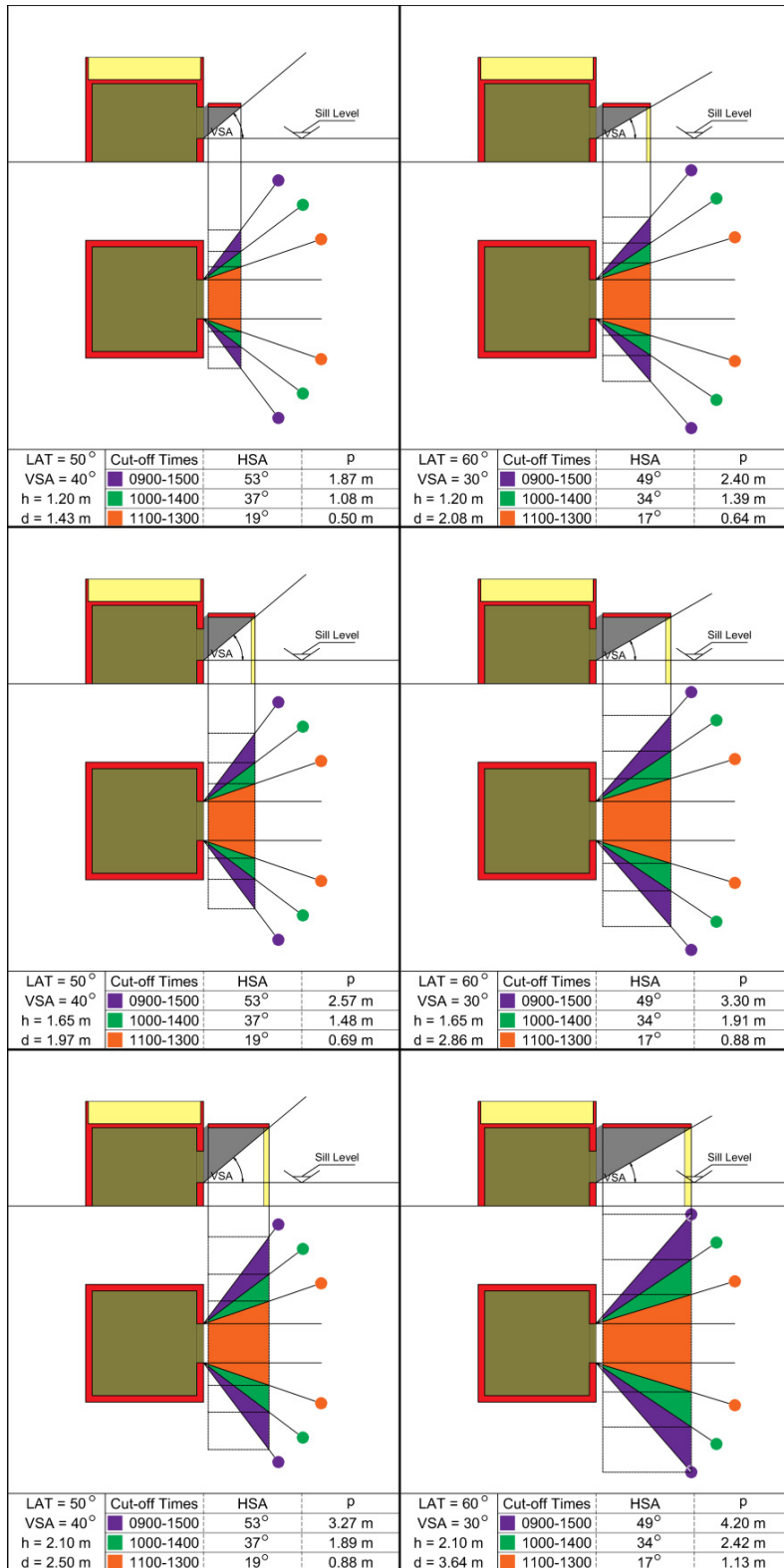

Fig. 3: Different configurations of horizontal shading devices with different shading heights (h) for Latitude 50° and 60°.

3.3. The design chart to determine (d/h) and ((p/h) of a horizontal shading device

The design chart shown in Fig. 4 is a combination of two charts; the first chart (on the right) determines the depth (d) of a horizontal shading device as a function of the latitude (LAT) and the shading height (h), and it is drawn using the formula:

$$\frac{d}{h} = \tan(LAT)$$

The second chart (on the left) determines the protrusion (p) of a horizontal shading device as a function of the latitude (LAT) and the shading height (h). This chart is drawn using the formula:

$$\frac{p}{h} = \tan(LAT) \times \tan(HSA)$$

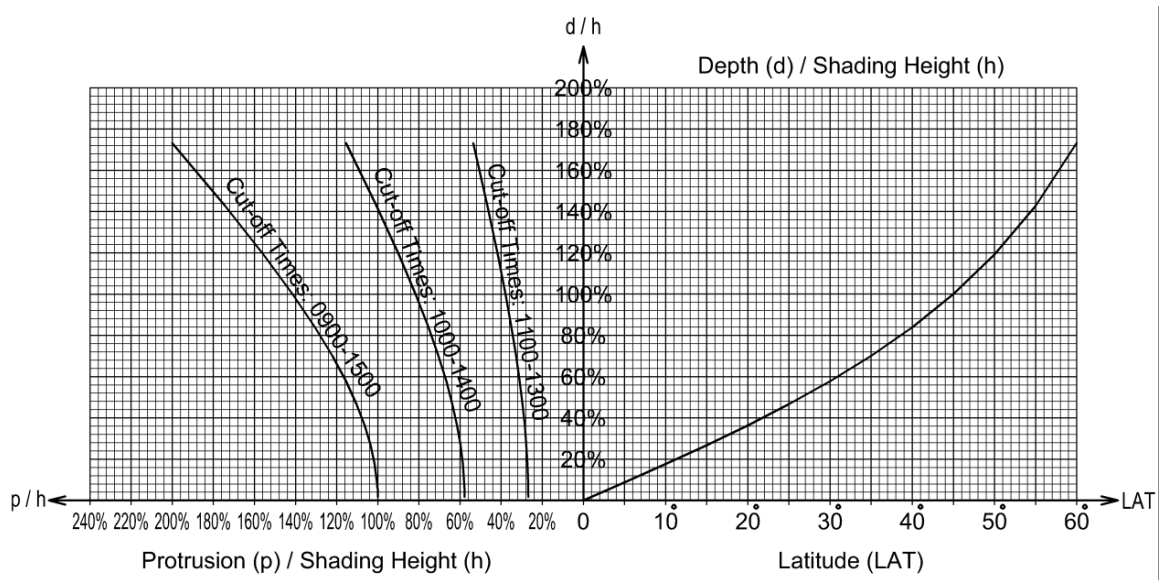

Fig. 4: The design chart to determine (d/h) and ((p/h) of a horizontal shading device

3.4. Description of the design chart

The design chart consists of two parts; right and left.

The right part is designed by the author in a previous research (Saifelnasr, 2013) from which we can find the ratio (d/h). It consists of two axes; the horizontal axis represents the range of latitudes from 0° (Equator) to 60° N and S that signifies the location of the city, while the vertical axis represents the ratio (d/h) between the required depth (d) of the horizontal shading device and the shading height (h).

The left part is the new addition to the design chart from which we can find the ratio (p/h). It consists of two axes; the vertical axis represents ratio (d/h) between the required depth (d) of the horizontal shading device and the shading height (h), while the horizontal axis represents the ratio (p/h) between the required protrusion (p) of the horizontal shading device and the shading height (h).

3.5. Using the design chart

To get the dimensions of a horizontal shading device as a function of the Latitude and shading height, both parts of the design chart are used as follows.

Enter the right part of the design chart on the horizontal axis with latitude (of the given city). Draw a vertical construction line from the marked latitude on the horizontal axis till it intersects the curve on the right part. From the point of intersection, draw a horizontal construction line till the ratio (d/h) is found on the vertical axis.

Enter the left part of the design chart with the obtained ratio (d/h). Extend a horizontal construction line from the obtained ratio (d/h) till it intersects one of the three curves on the left part according to the required cut-off times. From the point of intersection, draw a vertical construction line downwards till the ratio (p/h) is found on the horizontal axis.

To get the exact dimensions of a horizontal shading device, the depth (d) and the length (l) should be calculated as follows.

To calculate the depth (d) of the horizontal shading device, multiply the obtained ratio (d/h) by the needed shading height (h).

$$d = \frac{d}{h} \times h$$

To calculate the protrusion (p) of the horizontal shading device, multiply the obtained ratio (p/h) by the needed shading height (h) for the selected hours (cut-off times).

$$p = \frac{p}{h} \times h$$

To calculate the length (l) of the horizontal shading device, add the width of the equator-facing window (w) to double the value of protrusion (p) that is exceeding that width from both sides.

$$l = w + 2p$$

Example: using the design chart, it is required to find the dimensions of a horizontal shading device above a window whose width is 1.50 m at the southern façade in the city of Cairo, Egypt ((LAT) = 30° N), and in the city of Lecce, Italy (LAT = 40° N), given that the height needed to be shaded is 2.00 m and the required cut-off times are 1000-1400 hr and 1100-1300 hr respectively.

Solution: from the first curve on the left, the ratio (d/h) for Cairo and Lecce equals 58% and 84% respectively. From the second chart on the right, the ratio (p/h) for Cairo and Lecce equals 67% and 35% respectively (see Fig. 5).

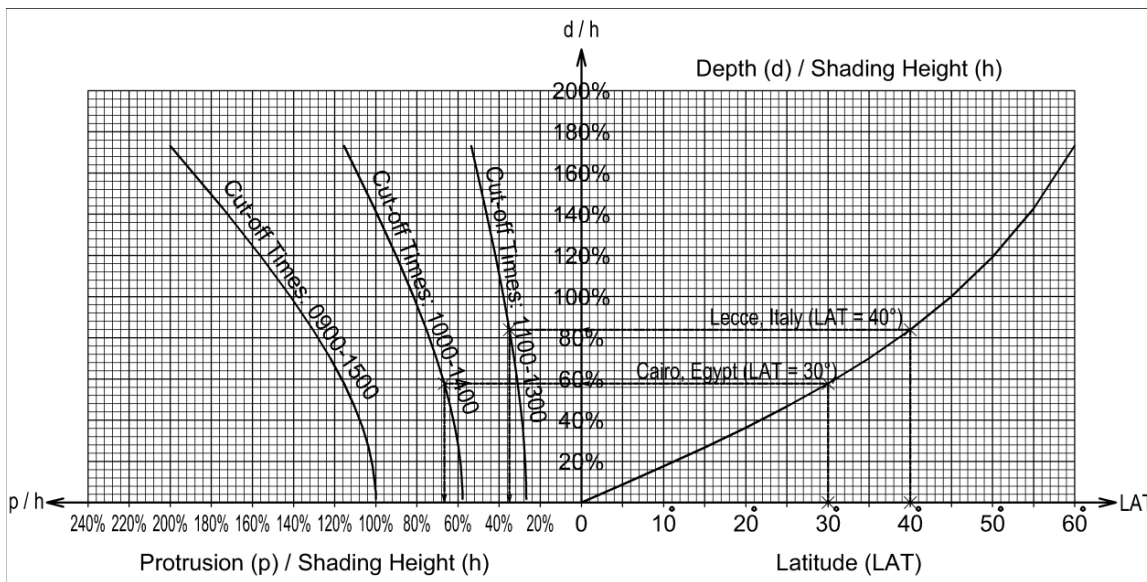

Fig. 5: Using the design chart for the city of Cairo, Egypt and Lecce, Italy

To get the exact dimensions of the horizontal shading device for Cairo:

$$d = \frac{d}{h} \times h = 0.58 \times 2.00 = 1.16 \text{ m}$$

$$p = \frac{p}{h} \times h = 0.67 \times 2.00 = 1.34 \text{ m}$$

$$l = w + 2p = 1.50 + (2 \times 1.34) = 4.18 \text{ m}$$

To get the exact dimensions of the horizontal shading device for Lecce:

$$d = \frac{d}{h} \times h = 0.84 \times 2.00 = 1.68 \text{ m}$$

$$p = \frac{p}{h} \times h = 0.35 \times 2.00 = 0.70 \text{ m}$$

$$l = w + 2p = 1.50 + (2 \times 0.70) = 2.90 \text{ m}$$

3.6. Notes on the design chart

The *position* of the shading height in relation to the façade doesn't not affect the dimensions of the horizontal shading device because shading design is a pure geometrical task (see Fig. 6).

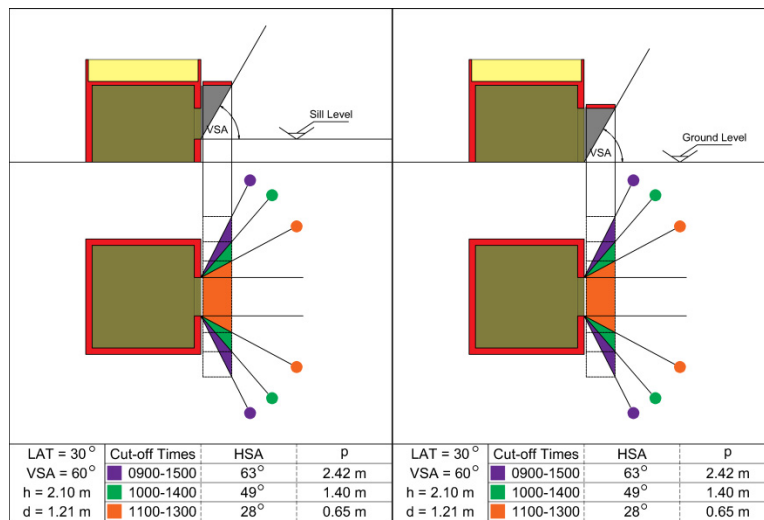

Fig. 6: The position of the shading height in relation to the façade doesn't not affect the dimensions of the horizontal shading device.

According to (Chiras, 2002), It is better to make a separation between the top of the window and the underside of the horizontal shading device in order to avoid the emission of heat off the device inside the space through the window. But this separation should not exceed a certain limit as it would lead to a notable increase in the dimensions of that device; depth (d) and length (l). Fig. 7, shows three different cases with varying separating distances between the top of the window and the underside of the horizontal shading device; 0.00 m, 0.45 m and 0.90 m respectively. The second and third cases are better than the first in turn of the heat that is reflected off the shading device to be emitted inside the space. But, they have got larger dimensions which would make the second alternative more suitable than the others.

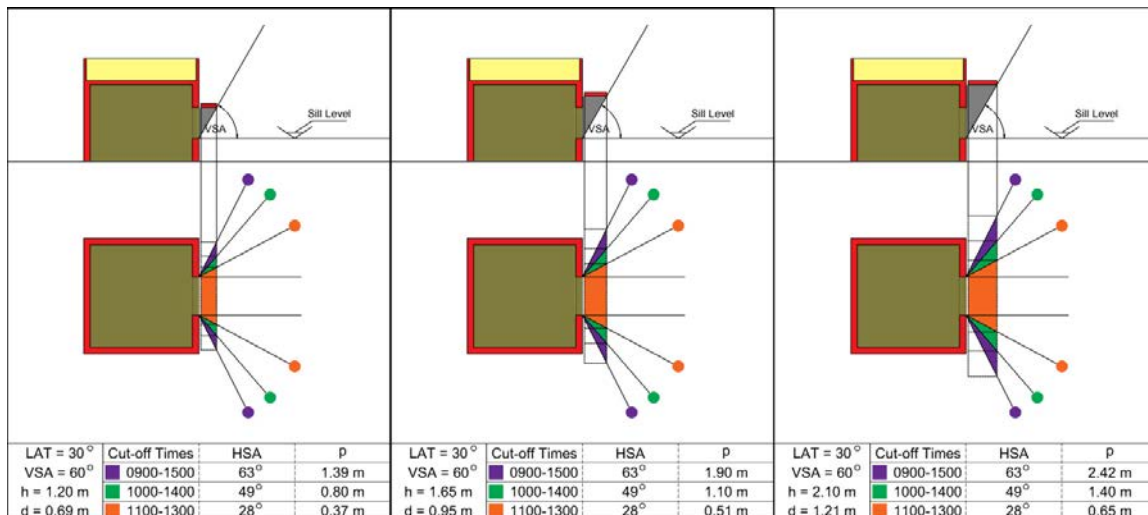

Fig. 7: Three different cases with varying separating distances between the top of the window and the underside of the horizontal shading device.

It is better to minimize the contact between the horizontal shading device and the window wall by creating a spacing (x) between them, to avoid heat transfer through conduction. The ratio (x/y) between the spacing (x) and the thickness of the device (y) would be exactly the same as that ratio (d/h) between the depth of the device (d) and the shading height (h), i.e., the right part of the design chart could be used to find the ratio (x/y).

$$\frac{x}{y} = \frac{d}{h} = \tan(LAT)$$

To calculate the spacing (x) of the horizontal shading device, multiply the obtained ratio (x/y) by the thickness of the device (y).

$$x = \frac{x}{y} \times y$$

Note that this spacing (x) would be subtracted from the calculated depth (d). And if this spacing exceeded the calculated value, the sun rays might be permitted through the space during the cut-off times.

The effective surface area of a horizontal shading device has the shape of a trapezoid whose smaller length equals to the width of the window opening (w) and its bigger length is exceeded by double the obtained protrusion (l = w + 2p). But for some reasons that might involve design or technical considerations, a rectangular shape could be used instead. But this rectangular surface area should cover the whole surface area of the trapezoidal shape, i.e., the length of the rectangle equals the bigger length of the trapezoid (l).

To overcome the elongated horizontal shading devices, especially in mid and upper latitudes when designing over a larger period of cut-off times, many small devices could have the same effect in blocking the same sun rays as a single large one, but they might obscure some of the view in case of a view window (Lechner, 2008). In case of using a number of louvers (n), the depth and protrusion of each smaller louver is equal to the obtained depth (d) and protrusion (p) from the design chart divided by their number (n), considering that their thickness is negligible.

$$depth\ of\ each\ louver = \frac{d}{n} \quad and \quad protrusion\ of\ each\ louver = \frac{p}{n}$$

It is clear that when the cut-off times are for a longer period, as from 0900 hr to 1500 hr (6 hours), the resulting dimensions; depth and length are relatively large when compared to shorter periods. In higher latitudes, a shorter period of time would be selected for blocking the sun, e.g., 1100-1300 hr or 1000-1400 hr. While, in lower latitudes, there might be a need to block the sun along a larger period of time. In this case the protrusion (p) of the device is very large compared to its depth (d), so it might be more suitable to use a horizontal projected structure such as:

overhangs, porches, arcades and loggias, because of the uniform broadening of that projected structure along the façade. In this case the right part only of the design chart is going to be used to identify the depth of that projected structure.

4. Discussion and Conclusions

This design chart can be used as a rule of thumb to find the dimensions of a horizontal shading device as a function of the latitude and the shading height, i.e., a quick tool for basic design decisions. That obtained dimensions would cause shading during the six months of summer and permits solar heating during the six months of winter.

The fact that it is a chart, makes it applicable for any location (city) within the low or middle latitudes, where shading is a need during the overheated period, i.e., summer.

The design chart could also be continued or upgraded in future researches. Another graph could be added so as to take account of other irregular configurations, or find more detailed dimensions. Their cost effectiveness could be investigated putting into consideration the difficulty in presenting the aspects concerning the economic values of different types of shading devices as mentioned by (Olgay & Olgay, 1976). The efficiency or the performance of such horizontal shading devices could be evaluated or studying their integration with other building systems, e.g., their effect on daylighting distribution inside the adjacent space.

References

- Brown, G. Z., & DeKay, M. (2001). *Sun, Wind & Light: Architectural Design Strategies*. New York: Wiley.
- Ching, F. D., & Shapiro, I. M. (2014). *Green Building Illustrated*. Hoboken, N.J.: Wiley.
- Chiras, D. D. (2002). *The Solar House: Passive Heating and Cooling*. White River Junction, VT: Chelsea Green Publishing Company.
- Dubois, M.-C. (2000). A Simple Chart to Design Shading Devices Considering the Window Solar Angle Dependent Properties. *Third ISES Europe Solar Congress*. Copenhagen, Denmark: Eurosun 2000.
- External Shading Devices*. (2004). Retrieved 08 12, 2015, from CLEAR (Comfort and Low Energy ARchitecture): http://www.new-learn.info/packages/clear/thermal/buildings/passive_system/solor_aces_control/external_shading.html
- Lechner, N. (2008). *Heating, Cooling, Lighting: Sustainable Design Methods for Architects*. Hoboken, N.J.: Wiley.
- Olgay, A., & Olgay, V. (1976). *Solar Control and Shading Devices*. Princeton: Princeton Architectural Press.
- Olgay, V., & Olgay, A. (1963). *Design with Climate: Bioclimatic Approach to Architectural Regionalism*. Princeton, N.J.: Princeton University Press.
- Saifelnasr, S. S. (2013). A Design Chart to Determine the Depth of a Projected Structure over an Equator-Facing Window for Automatic Seasonal Adjustment. *Building Simulation Cairo 2013 - Towards Sustainable & Green Built Environment*. Cairo: IBPSA-EGYPT.
- Szokolay, S. (2008). *Introduction to Architectural Science: The Basis of Sustainable Design*. Oxford: Architectural Press.
- Taylor, J. S. (1997). *A Shelter Sketchbook: Timeless Building Solutions*. White River Junction, Vt.: Chelsea Green Publishing Company.