



From electrons to cancer : Redox shift as a driving force of tumorigenesis

Romain Attal^{a,*}, Ashraf Bakkar^b, Frédéric Bouillaud^c, Anne Devin^d, Marc Henry^e,
Maxime Pontié^f, Miroslav Radman^g, Laurent Schwartz^h

^a Cité des Sciences et de l'Industrie, 30 avenue Corentin-Cariou, Paris, 75019, France

^b Modern Sciences and Arts University, 6th October, Giza, Egypt

^c Institut Cochin, INSERM U1016, CNRS UMR 8104, Université Paris-Descartes, 22 rue Méchain, Paris, 75014, France

^d IBGC, CNRS UMR 5095, Université de Bordeaux, 1 rue Camille Saint-Saëns, Bordeaux, 33077, France

^e Institut Le Bel, UMR 7177, Université de Strasbourg, 4 rue Blaise-Pascal, Strasbourg, 67070, France

^f Université d'Angers, Faculté des Sciences, Groupe Analyses et Procédés, 2 boulevard Lavoisier, Angers, 49045, France

^g Mediterranean Institute for Life Sciences (MedILS), Split, 21000, Croatia

^h Assistance Publique - Hôpitaux de Paris, Paris, France

ARTICLE INFO

Keywords:

Warburg effect
Cancer metabolism
Non-equilibrium thermodynamics
Glutamine
Methylene blue

PACS:

87.19.Xj
05.70.Ln

ABSTRACT

Cancer cells are very diverse but mostly share a common metabolic property: they are strongly glycolytic even though oxygen is available. Herein, the metabolic abnormalities of cancer cells are interpreted as modifications of the electric currents in redox reactions. A lower current in the electron transport chain, an increase of the concentration of reduced cofactors and a partial reversal of the tricarboxylic acid cycle are physical characteristics of several forms of cancer. The existence of electric short-circuits between oxidative branches and reductive branches of the metabolic network argue in favor of an electronic approach of cancer in the nanoscopic scale. These changes of electron flows induce a pseudo-hypoxia and the Warburg effect through succinate production and divert electrons from oxygen to biosynthetic pathways. This new look at cancer may have potential therapeutic applications.

1. Introduction

Life is a multiscale phenomenon based on the laws of physics and chemistry. More precisely, life can be described as a complex network of coupled cyclic, dissipative processes driven by the energy flow from a state of low entropy to a state of higher entropy [1,2]. In the nanoscopic domain, this energy flow is a mere cascade of electrons from an excited state to a lower energy state, but this statement sheds no light on complex biological phenomena at higher scales. The task of describing life starting from non-equilibrium thermodynamics and electronics is particularly difficult because each scale requires the identification of relevant parameters, currents, cyclic processes and driving forces. A change of focus necessitates a change of language to find new, effective variables and write down the phenomenological laws which govern them. Similarly, in the case of a disease like cancer, which affects the body at different levels, the search of a generic cure is often ineffective because a single drug targets a single process and does not take into

account phenomenological forces acting at other levels.

Our basic hypothesis is that the flow of energy and matter drives the information flow along the signaling pathways, from the nanoscopic scale of electrons to the macroscopic scale of the tumor and of the organism. In other words, energy dissipation drives information flow. The present work is an attempt to build an integrated picture of the hallmarks of cancer from a physical point of view.

2. Cancer metabolism

Although metabolic anomalies of cancer cells have been identified hundred years ago by Otto Warburg [3], the various forms of possible dysregulation have long delayed their recognition as a hallmark of cancer [4–6]. Indeed, the transition from a quiescent, differentiated state to a proliferative, dedifferentiated state of the cell is a multistep, gradual phenomenon [7]. Many biological parameters vary continuously during this transition. For instance, in head and neck squamous

* Corresponding author.

E-mail addresses: romain.attal@univscience.fr (R. Attal), ashraf.bakkar@msa.edu.eg (A. Bakkar), frederic.bouillaud@inserm.fr (F. Bouillaud), anne.devin@ibgc.cnrs.fr (A. Devin), henry@unistra.fr (M. Henry), maxime.pontie@univ-angers.fr (M. Pontié), miroslav.radman@medils.hr (M. Radman), dr.jaurentschiwartz@gmail.com (L. Schwartz).

<https://doi.org/10.1016/j.arres.2023.100087>

Received 4 October 2023; Received in revised form 12 November 2023; Accepted 12 November 2023

Available online 30 November 2023

2667-1379/© 2023 The Author(s). Published by Elsevier B.V. This is an open access article under the CC BY license (<http://creativecommons.org/licenses/by/4.0/>).

cell carcinoma, it has been discovered that increased glycolysis corresponds with tumor growth and immune invasion [8]. Similarly, it has been shown that glutaminase isoform 2 overexpression was connected to astrocytoma carcinogenesis and progression [9].

From a bioenergetic perspective, it is possible to identify a small number of parameters which describe the transition from a mainly oxidative metabolism - where most of the ATP is produced through oxidative phosphorylation (OxPhos) - to a glycolytic, glutamine dependent and anabolic mode - where substrate level phosphorylation (SLP) is higher. These parameters ($\text{ATP}_{\text{SLP}}/\text{ATP}_{\text{OxPhos}}$, $[\text{NADPH}]/[\text{NADP}^+]$, pH, electric currents and conductances, etc.) are not necessarily direct causes of the metabolic switch but rather simple, numerical characteristics thereof. During oxidative catabolism, the fate of most carbon atoms is to be oxidized into carbon dioxide. For instance, the oxidation of glucose changes the average oxidation number of carbon atoms from nearly 0 in carbohydrates to +4 in CO_2 . The function of the tricarboxylic acid (TCA) cycle (Fig. 9) and the mitochondrial electron transport chain (ETC) is to transfer electrons from carbon to oxygen and release energy in the form of ATP.

The Warburg effect, a paradoxical aerobic glycolysis, can be induced in some tumors - probably among others - by a decrease of the efficiency of the respiratory chains in the mitochondrial network [10]. Indeed, if the number of mitochondria decreases or if they do not function properly for any reason affecting one of their components, the ability to carry the electrons from reduced cofactors to oxygen will be compromised [11]. The electrons, still arriving steadily with glucose at the top of their energetic cascade must flow somewhere else since the mitochondrial network - at least in some tumors - is clogged. A way out is to flow into the anabolic pathways of least resistance operating in the cytoplasm, notably the fatty acid synthesis, the pentose-phosphate pathway and the oxaloacetate-malate-pyruvate pathway (Fig. 1), and along a reductive branch of the TCA cycle (Fig. 10).

Another metabolic peculiarity of some cancer cells is the high glutamine intake that provides energy for ATP synthesis and nitrogen for aminoacids. This high flow of glutamine feeds the TCA cycle in α -ketoglutarate. Under the force of redox shift, part of this α -ketoglutarate goes backward along a reductive branch of the TCA cycle, while another part follows the usual oxidative branch leading to fumarate or succinate (Fig. 2). Succinate dehydrogenase (SDH) deficiency is associated with several forms of cancer [12]. In human hepatocellular carcinoma, a low level of SDHB subunit induces an accumulation of succinate which slows down the degradation of hypoxia-inducible factor $\text{HIF}_{1\alpha}$ which in turn promotes the Warburg effect [13]. The oxidative branch started at α KG then stops at succinate. The role of succinate in the activation of pro-tumoral signaling pathways and in the Warburg effect suggests new therapeutic targets to regulate its concentration [14].

The metabolic rewiring of cancer cells can be seen as a superposition of the usual oxidative TCA cycle with parts of the reductive TCA (rTCA) cycle. The latter is the metabolic core of the most archaic cells [2,15] and is almost as ancient as life itself. In a reductive environment, this cycle can become active in parallel with its modern, oxidative version. Indeed, there are many reports on the involvement of the reductive TCA cycle in cancer growth [16–18].

3. Cancer thermodynamics

It is often stated that cancer results from an accumulation of mutations in somatic cells: the expression of proto-oncogenes is activated whereas that of tumor suppressor genes is inhibited, regardless of the nature of carcinogenic factors [7,19]. Unregulated oncoproteins activate proteases which destroy the extracellular matrix, deteriorate the cell-cell contacts and promote the epithelial-mesenchymal transition [7]. However, nuclear graft experiments [20,21] suggest that the phenotype of oncogenic mutations is subject to modifications by cytoplasm. Consequently, DNA mutations are not “the primary cause of cancer” (if such a thing exists) and these observations cast some doubts on the purely

genetic approach of cancer [22]. In the following, we will describe the role of electron flow in the transition between catabolism and anabolism, and advocate for the importance of this step in the process of tumorigenesis.

3.1. Conductances and forces

In a linear electric network, the electric current, I_a , in each branch a , is a linear function of the tensions, U_b , in all the branches, b , of the network: $I_a = \sum_b L_{ab} U_b$. The coefficients L_{ab} are the conductances of the network. This is a generalisation of the usual Ohm's Law, $I = GU$, valid for a single ohmic (i.e. linear) conductor, of conductance G . In linear, near equilibrium thermodynamics [23,24] the currents, J_a , can be reaction rates, particle currents, heat fluxes, etc. The forces, X_b , that drive these currents can be concentration differences or temperature gradients, affinities of chemical reactions, membrane potentials, etc. The linearity hypothesis states that there exists a matrix, $L = [L_{ab}]$, of (generalised) conductances such that:

$$J_a = \sum_b L_{ab} X_b. \quad (1)$$

The power dissipated by the network of physico-chemical processes, $P = \sum_c X_c J_c$, is then a quadratic function of X :

$$P = \sum_{ab} X_a L_{ab} X_b. \quad (2)$$

In a cell, the expression of genes modulates the concentration of various enzymes such as catalysts, hence modifies only the *kinetics* of chemical reactions. Therefore, genetics modifies the matrix L of conductances. On the other hand, the thermodynamical forces, X_b , are gradients of physical quantities or affinities of chemical reactions, $A = \sum_i \nu_i (-\mu_i/T)$, where the chemical potentials, μ_i , of reactants and products depend on their respective concentrations and on the temperature, T . The stoichiometric coefficients, ν_i , are fixed by the process under consideration. The genetic approach to cancer focuses on the modification of the conductance coefficients, L_{ab} , whereas the metabolic approach tries to modify the thermodynamical forces, X_b .

In mechanics, Newton's law states that forces are the cause of the change of motion. Similarly, the generalized forces, X , can be considered as a cause of the currents, J . However, causality relations are difficult to identify in biology because life is based on the existence of positive feedback loops, where effects reinforce causes. When possible, the identification of phenomenological forces provides an effective causal structure to a system of biological processes. These cyclic dissipative processes have their own dynamics and form a network whose topological stability underlies the existence of life itself.

3.2. A reduced environment drives tumor growth

Cancer cells evolve in a reduced environment [25]. In order to quantify this statement we define the *redox shifts*:

$$\begin{aligned} \rho &:= \log \left(\frac{[\text{NADH}]}{[\text{NAD}^+]} \right) \\ \rho_p &:= \log \left(\frac{[\text{NADPH}]}{[\text{NADP}^+]} \right) \end{aligned} \quad (3)$$

where the logarithm can be taken in any fixed basis. ρ and ρ_p are thermodynamical forces and their variations drive the system away from equilibrium [23]. Let ρ' and ρ'_p be their counterparts in cancer cells. According to [26], the ratio $[\text{NADH}]/[\text{NAD}^+]$ can be multiplied by five and $[\text{NADPH}]/[\text{NADP}^+]$ can be multiplied by ten in cancer cells. During the cell cycle, ρ' and ρ'_p undergo larger variations than ρ and ρ_p , respectively. In particular, the S-phase shows a high peak of ρ' and ρ'_p

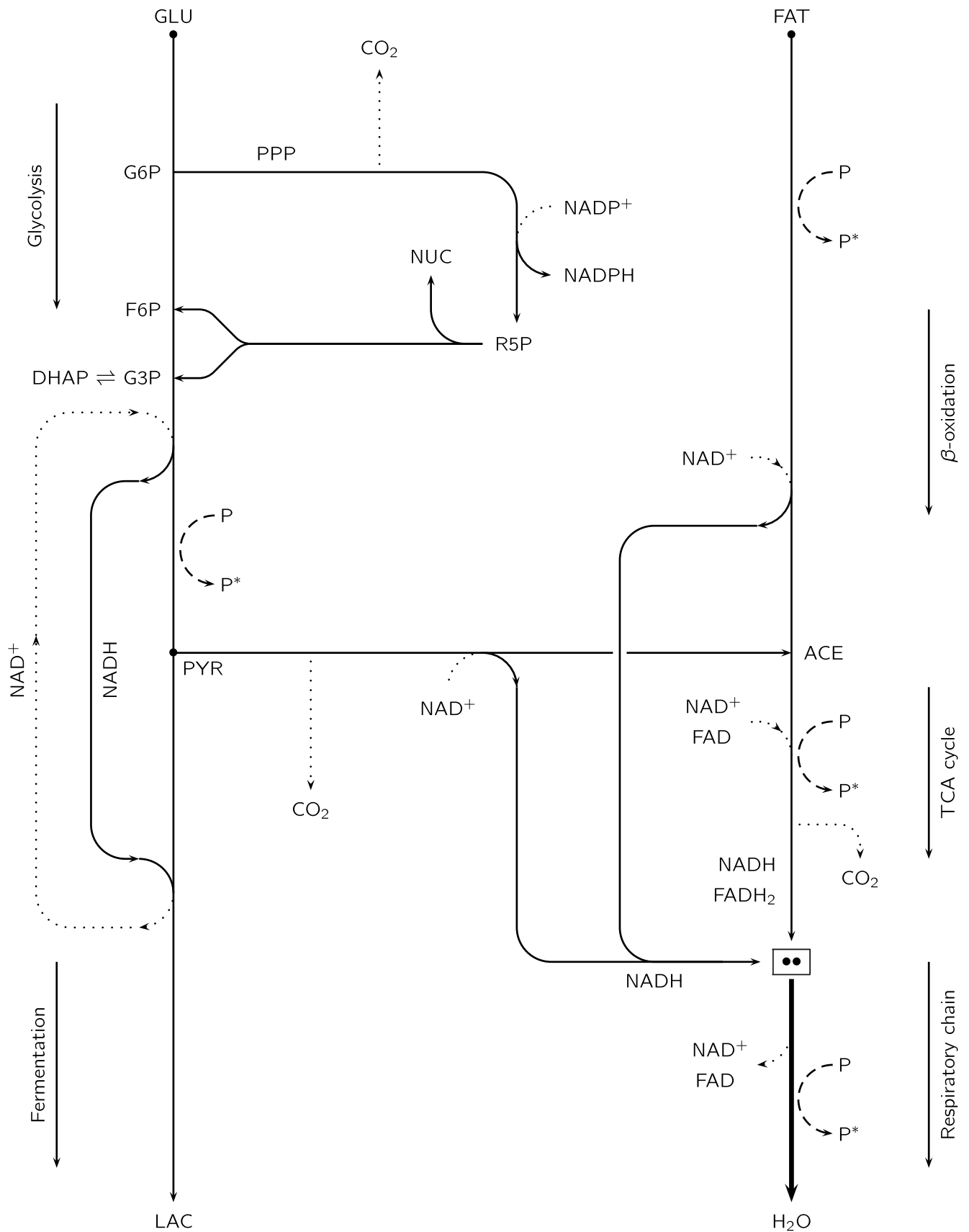

Fig. 1. Electron and phosphate flows in a toy model of metabolism. The two black dots represent the electron pairs extracted from NADH or FADH₂ and P* represents high energy phosphate carriers (mainly ATP).

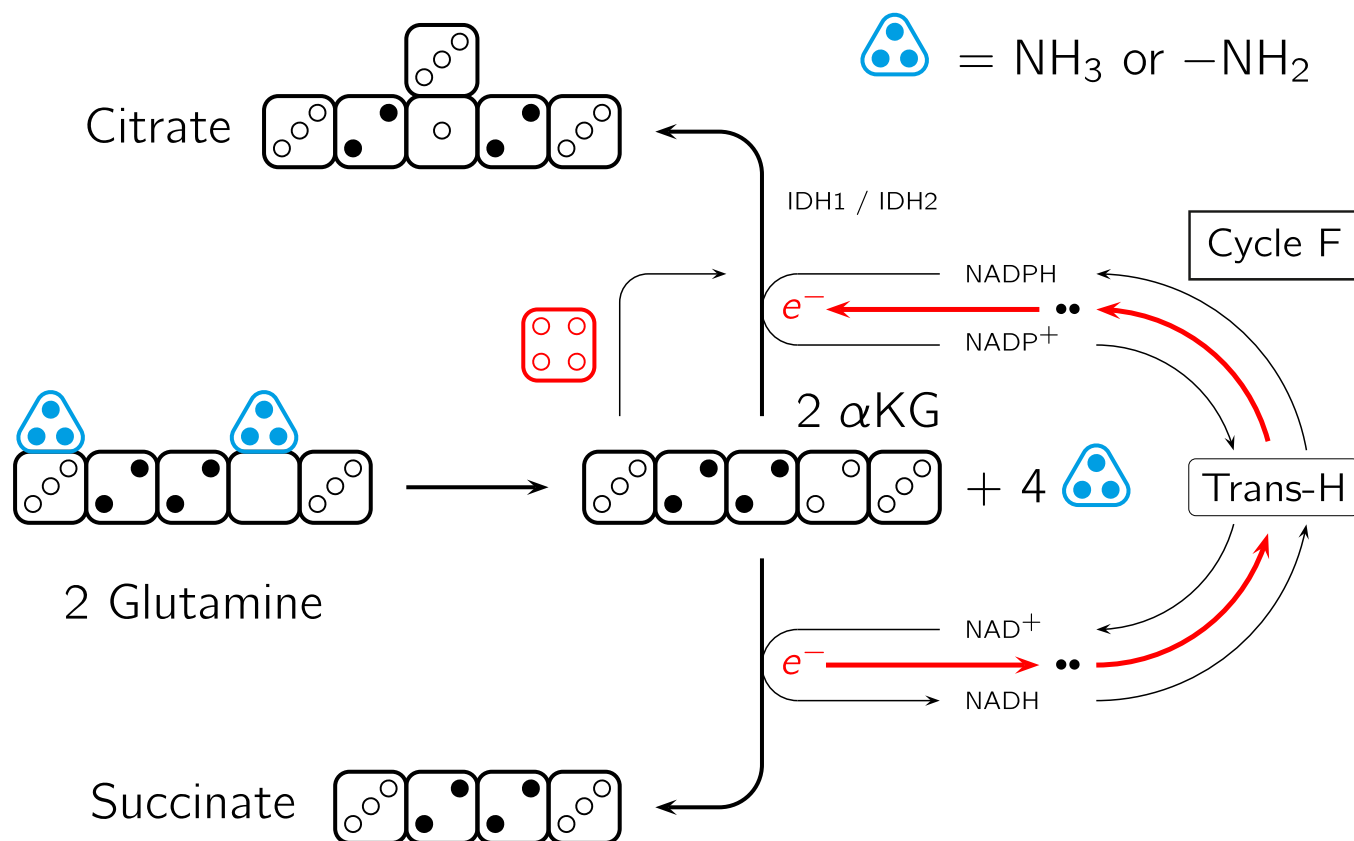

Fig. 2. Glutamine feeds the TCA cycle with α -ketoglutarate, a part of which is reduced into citrate and another oxidized into succinate. Nitrogen is released in NH_3 or is available for amino-acid synthesis. The transhydrogenase (Trans-H) bound to the mitochondrial membrane makes an electric short-circuit between the oxidative branch and the reductive branch of the modified TCA cycle.

whereas ρ and ρ_p follow almost flat curves. The pentose-phosphate pathway produces ribulose-6-phosphate (R5P) needed for nucleic acid synthesis, as well as NADPH which participates in the creation of a reduced environment and drives fatty acid synthesis for membrane formation. This is in accordance with computer modelling, which suggests a redox switch in cancer cells [27,28]. Indeed, biosynthetic pathways are active when reduced cofactors are present in high concentrations (Table 1).

3.3. Mitochondrial impairment increases the cytoplasmic pH

In a metal, electrons can move collectively to build an overall electric current under the action of an electric field. In semiconductors, electrons and holes (electron deficiencies, of positive charge) are the free charge carriers and move in opposite directions. In an aqueous solution, there are neither free electrons nor holes, but anions and cations can move in opposite directions to generate an electric current transferred to the outside, as in a battery. In a metabolic network, the charge carriers are of different types: organic substrates with reduced or oxidized carbon atoms; reduced coenzymes (NADH , FADH_2 , NADPH); electron carriers embedded in the inner mitochondrial membrane (quinones, cytochromes). These various molecules undergo transformations that allow the electrons to reach their final destinations: O - H bonds (*de novo* water formation) or C - C bonds (synthesis of biomolecules).

An altered electron transport chain leads to an accumulation of reduced cofactors and builds up a reduced environment. This increased electronic density in the valence shell of carbon atoms modifies the usage of the TCA cycle, some of its steps being processed backward with respect to the oxidative cycle [10,29]. This reduces the overall formation of CO_2 and carbonic acid (H_2CO_3), hence the cytoplasmic pH increases. This alkalinisation of the cytoplasm is correlated with the increase of the

concentrations of reduced cofactors. Indeed, the intracellular pH in the cancer cells oscillates between 7.2 and 7.5. The increase of internal pH is parallel to a decrease of external pH, due to the release of lactic acid by cancer cells [30]. Lactic acid is a nutrient for the surrounding immune cells and for the vascular cells [31,32]. This acidification of the extracellular environment favors the cells that are best adapted to these hostile conditions. Therefore, correcting the intracellular pH may be an adjunct to a metabolic treatment [33]. Interestingly, it has been shown that a change in pH_i from 7.1 to 7.5 may help cancer cells to retain pyruvate kinase M2 (PK-M2) maximally active and responsive to FBP-mediated allosteric activation, resulting in lactate production and enhanced cell proliferation [34]. It is well known that PK-M2 is expressed in cancer cells and leads to the diversion of pyruvate at the last step of glycolysis to lactate dehydrogenase, thus increasing the lactate yield [7]. The export of lactic acid lowers the pH of the extracellular environment. Moreover, one can observe an increased survival when molecules which prevent proton extrusion from the tumor cells are combined with standard chemotherapy [35–37].

3.4. ROS and lactate as wastes of cancer cells

What is the fate of oxygen that can not catch electrons at the end of the respiratory chain? The strongest oxidant in the cell, O_2 will catch electrons elsewhere and form H_2O_2 and reactive oxygen species (ROS): O_2^- , HO^\bullet , etc. Glutathione (GSH) reduces these reactive oxygen species and generates the dimer GSSG. NADPH reduces GSSG to form NADP^+ , which oxidizes G6P and 6PG along the pentose-phosphate pathway (Fig. 8). This glutathione redox cycle uses NADP^+ as an electron carrier for this pathway and produces ribose-5-phosphate (R5P), an essential ingredient of nucleotides.

Lactate produced by strongly glycolytic cancer cells can be either

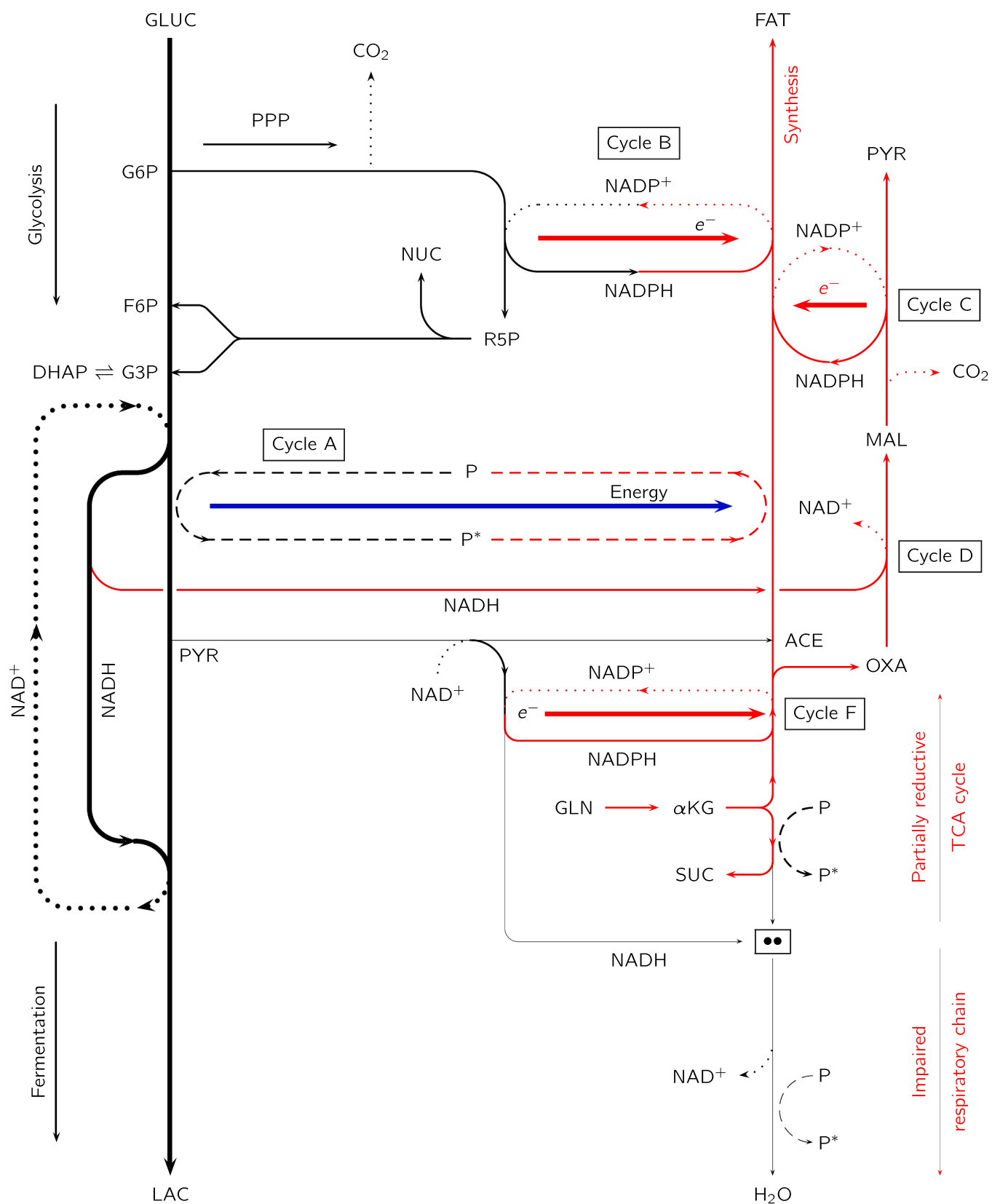

Fig. 3. When the electric conductance of the mitochondrial respiratory chain is too low, the electrons flow in the upper branches of the circuit, through cytosolic NADP shuttles and mitochondrial NAD shuttles. High energy phosphates (P^{*} = ATP, GTP, etc.) produced by glycolysis are consumed by the biosynthesis of fatty acids. NUC = nucleotides.

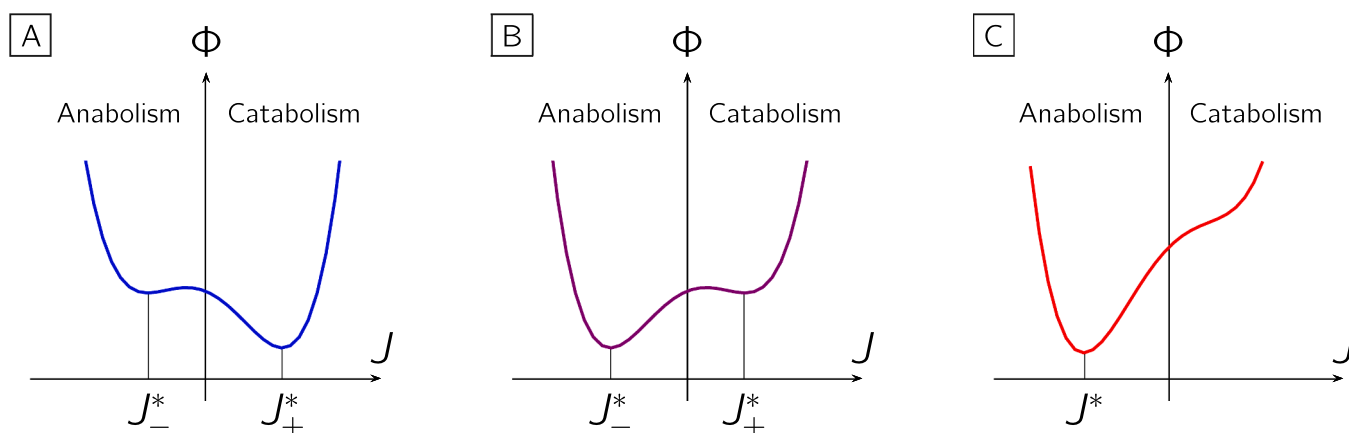

Fig. 4. In a steady state, the rate of entropy production, Φ , reaches a local minimum. The metabolism can be mainly catabolic (A) or mainly anabolic (B). In case C, the metabolism is strongly anabolic.

oxidized into CO_2 by other cells (in the brain), or transiently accumulated within the cell or excreted to form lactic acid. It constitutes an oxygen debt that is to be reimbursed in the short term. In contrast, biosynthesis of lipids is an oxygen debt in the long term because the ultimate degradation of stored fatty acids requires a postponed oxidation into carbon dioxide.

It seems though that electron flow, carried by the NADH/NAD⁺ shuttles, could be involved in the carcinogenesis processes and the Warburg effect. However, no clear interpretation or causal relation between electron flow and cancer phenotype emerges yet. The fundamental driver of cellular growth in cancer cells is not glucose fermentation. Instead, the latter is a secondary effect of the saturation of the malate-aspartate shuttle (MAS), the glycerol-3-phosphate shuttle (G3PS) and the mitochondrial NADH shuttles [38]. Furthermore, when the need for NAD⁺ exceeds the need for ATP, cells start aerobic glycolysis and the activation of pyruvate dehydrogenase (PDH) increases the ratio $[\text{NADH}]/[\text{NAD}^+]$, which inhibits cell growth. However, no clear picture has been established yet for the consequences of the saturation of these shuttles (MAS and G3PS) and a higher demand of NAD⁺. Herein, we dig deeper, at the electronic level to try to elucidate the role of redox shifts in carcinogenesis.

4. Cancer electronics

Since cells extract their energy from nutrients by a sequence of redox reactions, the main actors of cellular metabolism are the electrons of the valence shell of these organic molecules. We will focus on carbon atoms, the only ones whose oxidation number changes significantly. For instance, the carbon atom of CO_2 has oxidation number $\omega = +4$ and will be represented by a box containing four holes (◦), whereas acetate, CH_3COO^- , is represented by two adjacent boxes: one with three holes for the carboxyl group ($\omega = +3$) and the other with three dots (•) for the methyl group ($\omega = -3$). For ammonia and the amino group, $-\text{NH}_2$, $\omega = -3$ (Table 2).

We define the *average oxidation number*, $\bar{\omega}$, of the carbon atoms of an organic molecule by the following formula:

$$\bar{\omega} = \frac{\text{Number of holes (◦)} - \text{Number of electrons (•)}}{\text{Number of carbon atoms (□)}} \quad (4)$$

$\bar{\omega}$ increases during catabolism and decreases during anabolism. We can represent the main metabolic pathways in a diagrammatic form in order to keep track of these electrons. Our box diagrams represent the flow of electrons during glycolysis (Fig. 6), ketogenesis (Fig. 7) and along the pentose-phosphate pathway (Fig. 8).

4.1. Glycolytic electric network

Glycolysis and lactic fermentation form a universal sequence of reactions (Fig. 6). Glycolysis polarizes the carbon skeleton and splits it in two pyruvate molecules. After pyruvate, two routes are possible: either oxidize and decarboxylate pyruvate into acetate, or give back two electrons to pyruvate and make lactate. The latter option is redox neutral whereas the former feeds the pool of NADH. An increase of the ratio $[\text{NADH}]/[\text{NAD}^+]$ then favors the production of lactic acid due to the relative lack of NAD⁺ to oxidize pyruvate into acetate.

4.2. The pentose-phosphate pathway

After phosphorylation of glucose, G6P can either be isomerized into F6P or follow a longer process, the pentose-phosphate pathway (PPP) that extracts six CO_2 molecules from six G6P and provides two G3P, four F6P, twelve pairs of electrons and a single inorganic phosphate, P_i (Fig. 8). This “1/6 carbon tax” taken from glycolysis by PPP replenishes the pool of cytoplasmic R5P that is necessary for nucleic acid synthesis. Moreover, the electrons thus extracted are carried away by NADPH, which is used in cytoplasmic biosynthesis reactions.

4.3. Aminoacid biosynthesis

Two of the key metabolic alterations that occur in cancer are the increased production of lactate via the glycolytic pathway and the enhanced utilization of glutamine to maintain the anabolic activities of tumor cells [39]. Indeed, It has been shown that under glucose deprivation, lactate and glutamine enhance NADPH generation via isocitrate dehydrogenase 1 (IDH1) and malic enzyme 1 (ME1), respectively. Lactate participates in the production of isocitrate, and malate derived from glutamine in the mitochondria is used to generate NADPH in the cytosol [40]. This represents a key source of NADPH for the highly proliferative cancer cells deprived of glucose and which cannot rely heavily on the pentose-phosphate shunt. Moreover, glutamine metabolism is a nitrogen donor for nucleotide and amino acid synthesis. Acetyl-CoA, a byproduct of this process, feeds lipid biosynthesis as well as the TCA cycle which maintains NADPH production. Rapidly proliferating tumor cells exhibit the Warburg effect resulting in a shift in glucose carbon away from the TCA cycle. Consequently, the flow of glutamine increases to maintain anabolic processes and support rapid cell growth with increased NADPH and ammonia generation [41]. Moreover, it has been shown that, when the electron transport chain is impaired, utilization of NADH is perturbed, which leads to cytosolic reductive carboxylation of glutamine and hence cytosol-confined NADH recycling in a reaction catalyzed by malate dehydrogenase 1 (MDH1)

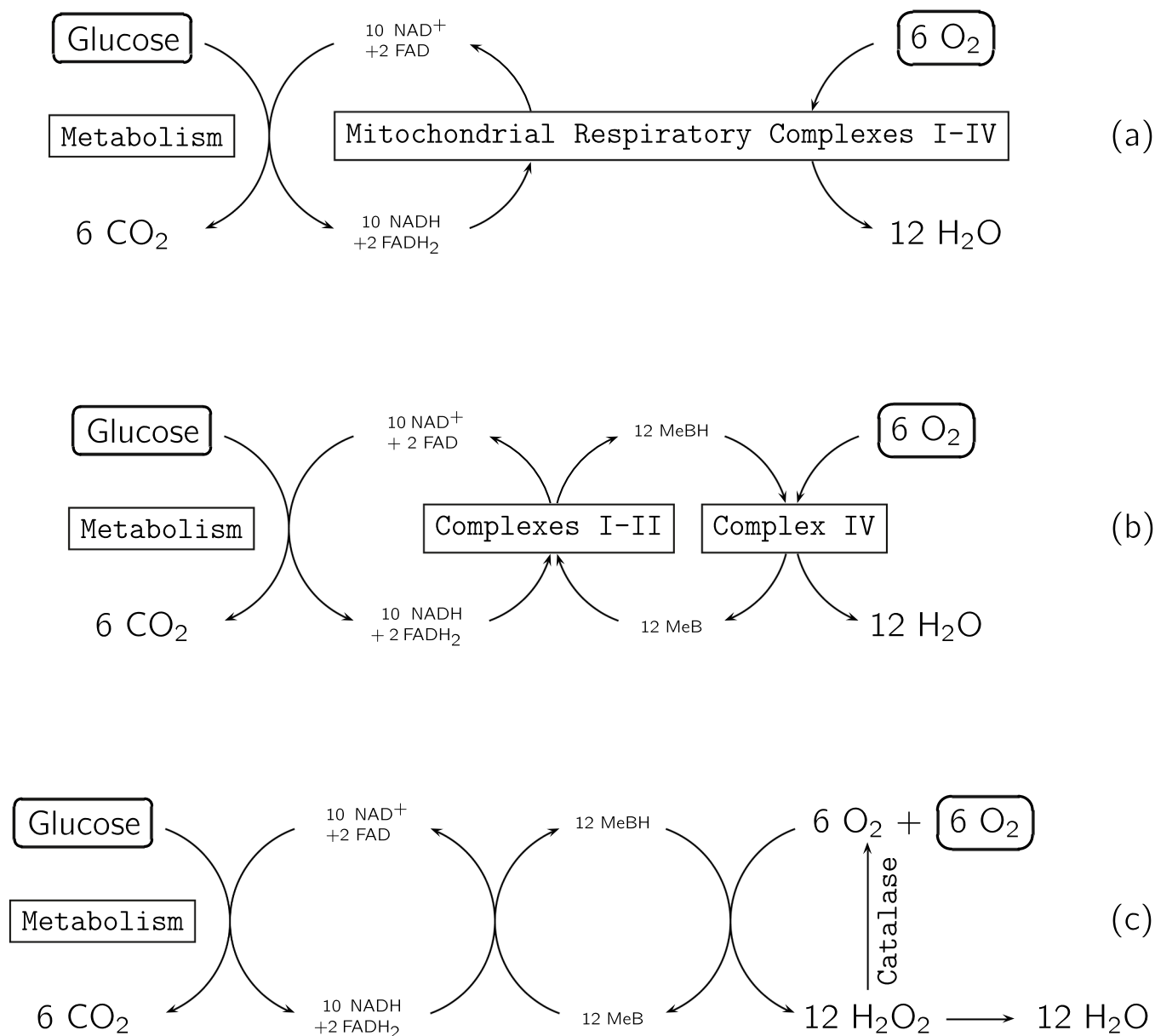

Fig. 5. Case (a) shows the full cellular oxidation of one glucose molecule. In case (b), the reduction/oxidation cycle of MeB bypasses complex III in the mitochondrial respiratory chain. In case (c), the redox cycle of MeB takes place without contribution of any mitochondrial complex. MeBH oxidation by dioxygen generates H_2O_2 eliminated by catalase.

Table 1
Anabolic processes are enhanced by high concentrations of reduced coenzymes NADH and NADPH.

The role of NADPH and NADH in some anabolic processes			
Anabolic Process	Main end products	Coenzymes	Enzymes
Gluconeogenesis	Glucose	NADH	G3P-dehydrogenase
<i>De novo</i> fatty acid synthesis	Fatty acids	NADPH	Fatty acid synthase
Cholesterol synthesis	Cholesterol	NADPH	HMG-CoA reductase
Steroid synthesis	Steroids	NADPH	Steroid-21 mono-oxygenase
Non-essential amino acids	Alanine, etc.	NADPH	Glutamate dehydrogenase

[42].

4.4. Ketogenic pathways

Ketogenesis starts from acetyl-CoA and synthesizes in a few steps aceto-acetate (ACE-ACE), 3-hydroxybutyrate (3HB) and acetone (ACT). Ketogenesis can use part of the acetyl-CoA and NADH accumulated after glycolysis to produce exportable and usable fuel for most of our cells. Ketogenesis is a pseudo-respiration since it generates CO_2 and drives a few electrons away from the cell (Fig. 7). This complementarity of ketogenesis with respect to glycolysis, the TCA cycle and the respiratory chain is at the basis of the ketogenic diet for cancer. However, for a ketogenic diet to be efficient, it is necessary to lower the electron flow also at the top of glycolysis, by reducing drastically the glucose concentration and the total energy intake. According to [43], a hypocaloric ketogenic diet is a powerful tool to lighten the burden of cancer. However, the possibility that some cancer cells use ketone bodies as fuel

Table 2

Box diagrams and oxidation numbers of the main functional groups.

Functional group	Oxidation number	Box diagram
CH ₄	$\omega = -4$	
-CH ₃	$\omega = -3$	
-CH ₂ -	$\omega = -2$	
-CH=	$\omega = -1$	
-CHOH-	$\omega = 0$	
-COH	$\omega = +1$	
-CO-	$\omega = +2$	
-COOH	$\omega = +3$	
CO ₂	$\omega = +4$	
-NH ₂	$\omega = -3$	

suggests that blocking this pathway, for instance via the inhibition of succinyl-CoA transferase (SCOT/OXCT1) and β -hydroxybutyrate dehydrogenase (BDH1), may have therapeutic effects [44–46]. Note that the carbon atoms of ketone bodies have a negative average oxidation number: $\bar{\omega} = -4/3$ for acetone and $\bar{\omega} = -1/2$ for 3-hydroxybutyrate. This makes ketone bodies an electron sink which lowers the intracellular redox shift.

4.5. Mitochondrial respiratory chain

Viewed as an electric circuit, the mitochondrial respiratory chain is (almost) linear:

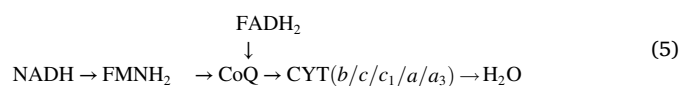

NADH gives its two labile electrons to FMN. FMNH₂ and FADH₂ give their electrons to the coenzyme-Q (CoQ = ubiquinone). These electrons go through cytochromes *b*, *c*, *c*₁, *a*, *a*₃, sequentially. At the end of the respiratory chain, dioxygen takes these electrons and free protons to form water. Each electron transport chain is equivalent with a single ohmic conductor and the mitochondrial network is equivalent with a large number of such conductors in parallel, with CoQ and H₂O as common end points. The conductance of each branch of this electric circuit depends on the efficiency of the enzymes and coenzymes, on the mobility of electron carrying molecules (in particular, that of CoQ in the mitochondrial membrane), on the lipidome of the inner mitochondrial membrane and on many other physical or chemical factors. For instance, if the length of cardiolipin alkyl chains is not adequate, the cytochromes do not fit properly in the membrane and can not play correctly their role of electron carriers [43,47].

4.6. Catabolic electric network

We now assemble the aforementioned pathways in a simplified model of metabolism where the only nutrients are glucose (GLUC) and fatty acids (FAT), as in Fig. 1 which represents an electric circuit (solid lines) coupled with a phosphate circuit (dashed lines) and a circuit of coenzymes (dotted lines, when the latter are oxidized). The electrons are extracted from the valence shell of organic substrates and carried by

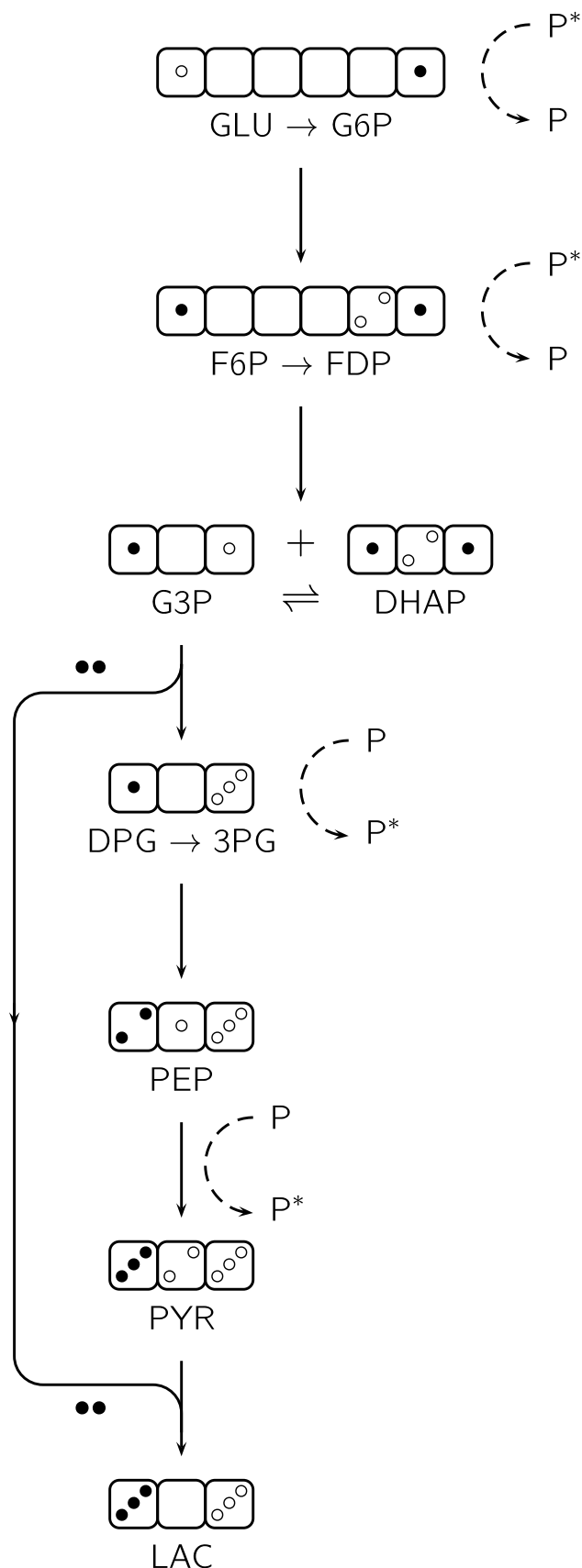

Fig. 6. The motion of electrons (•), holes (◦) and phosphates (P/P*) during glycolysis and fermentation.

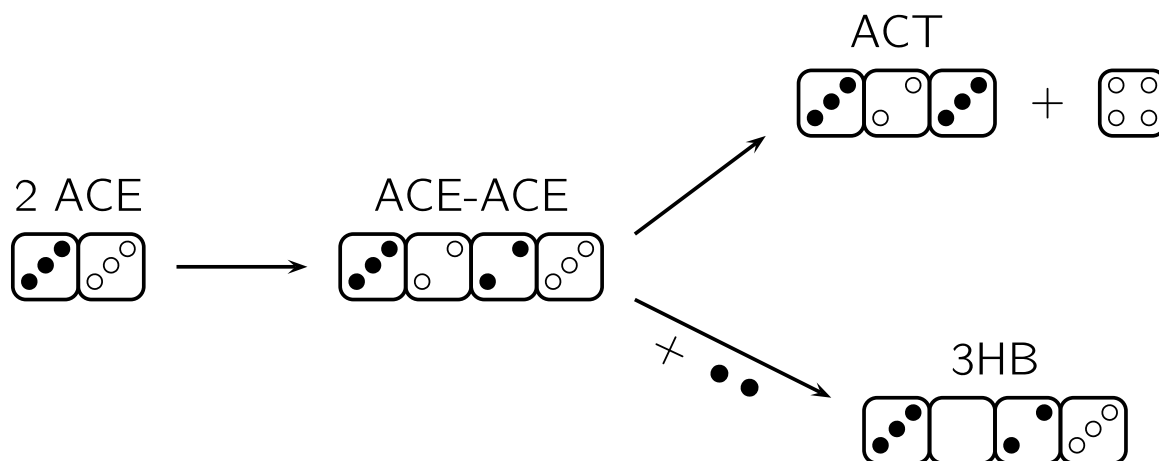

Fig. 7. Ketogenesis produces three ketone bodies: aceto-acetate (ACE-ACE), acetone (ACT) and 3-hydroxybutyrate (3HB).

hydrogen atoms transported by coenzymes. This network is characterized by the recycling of NAD, NADP and FAD which play the role of electronic shuttles between various oxidizing branches of the network and the ultimate respiratory chain. These cycles define the steady state of the cellular metabolism. When the electric conductance of the respiratory chain is normal, the electrons can be transported by the various carriers located on the inner mitochondrial membrane and finally reduce oxygen into water.

The transition from respiratory catabolism to fermentary anabolism can be induced by a decrease of the electron flow in the respiratory chain. This phenomenon can have many causes, among which: (a) the reversible, immediate kinetic inhibition of the electron transport chain by a high glucose concentration (Crabtree effect [48]). (b) the number of mitochondria can be low; (c) the phospholipids which form the inner mitochondrial membrane (cardiolipins) can be defective and the contact between the successive electron carriers can be altered [43,47]; (d) the total area of the inner membranes of the mitochondrial network can be reduced, as can be seen in electron microscopy of mitochondria from cancer cells [43]; (e) a saturation of the aspartate-malate shuttle and/or the glycerol-3-phosphate shuttle across the mitochondrial membrane [38]; (f) any combination of the previous factors. The lowering of this electronic conductance reduces the mitochondrial production of ATP by OxPhos and enhances the cytoplasmic production of ATP by glycolysis through the retrograde response [43]. When the electron current in the $\text{ACE} \rightarrow \text{H}_2\text{O}$ branch is weak, NADH accumulates and inhibits the action of PDH, the current from pyruvate to acetyl-CoA is low and pyruvate is reduced into lactate and regenerates NAD^+ . This NAD shuttle establishes an electronic short circuit which accelerates glycolysis. A high glycolysis rate facilitates a higher flow along the pentose-phosphate pathway, which increases the cytoplasmic ratio $[\text{NADPH}]/[\text{NADP}^+]$. The synthesis of fatty acids from ACE, NADPH and ATP is then favoured over the mitochondrial β -oxidation.

4.7. TCA cycle in cancer cells

The carboxylic acids which participate in the TCA cycle form a universal core of the metabolism of all known forms of life [2,49]. Healthy plant cells can use this cycle in different flux modes according to the cell type and physiological context [50]. In a healthy animal cell working in an oxidizing environment, this cycle is used as a catabolic machine to oxidize acetate and send electrons to the mitochondrial respiratory chain. In the strongly reducing atmosphere of the early Earth and until the accumulation of oxygen in the atmosphere, about two billion years ago, the TCA cycle could work backward as an anabolic machine [49,51]. In a cancer cell, the reducing environment may reverse some steps of the TCA cycle [10,16,29]. When the output of the

process is fumarate or succinate, the latter are exported to the cytosol where they inhibit prolyl-hydroxylase, which degrades $\text{HIF}_{1\alpha}$. The latter promotes aerobic glycolysis and the excess of fumarate or succinate, due to the electronic short-circuit in the TCA cycle, thus triggering the Warburg effect [52].

Glutamine metabolism is a target of critical importance in the treatment of cancer because glutamine provides α -ketoglutarate and pushes the TCA cycle in both directions, oxidative and reductive, in some cancer cells [16,53,54]. In melanoma cells, both isoforms 1 and 2 of isocitrate dehydrogenase are used to reduce αKG into isocitrate [17]. An electric short-circuit is thus created between an oxidative branch and a reductive branch of the TCA cycle (Figs. 2 and 11). Moreover, the production of ammonia by deamination of glutamine has a devastating effect on distant muscle tissue which releases aminoacids, in particular glutamine. The latter produces more ammonia and this process initiates the vicious cycle of cachexia [43,52]. These partial reversals of the TCA cycle come with electric short-circuits between an oxidative branch and a reductive branch, through a NADH shuttle (Fig. 10) or through a double NADH-NADPH shuttle mediated by transhydrogenase. This situation is similar to the cytoplasmic short-circuit between the pentose-phosphate pathway and the fatty acid synthesis, where the electrons are carried by NADPH (Fig. 3).

4.8. Anabolic electric network

When the conductance of the respiratory chain is low and the cellular metabolism becomes strongly glycolytic, the electron flows are modified in several ways. In this transition, some currents are slowed down and others are enhanced but most importantly this new mode is characterized by several cycles (Figs. 10 and 3) triggered by the redox shift:

- **Cycle A** is the ATP shuttle between glycolysis and fatty acid synthesis ;
- **Cycle B** is the NADP shuttle between the pentose-phosphate pathway and the fatty acid synthesis ;
- **Cycle C** is the NADP shuttle between oxidation of malate into pyruvate and the fatty acid synthesis ;
- **Cycle D** is the NAD shuttle between glycolysis and the cytosolic reduction of oxaloacetate into malate.
- **Cycle E** is the NAD shuttle between the oxidative and reductive branches of the TCA cycle.
- **Cycle F** is the double shuttle (NAD and NADP) induced by oxidation and reduction of α -ketoglutarate produced by glutamine (Fig. 2).

These positive feedback loops reinforce each other and enhance various anabolic processes. Indeed, the partial reversal of the TCA cycle

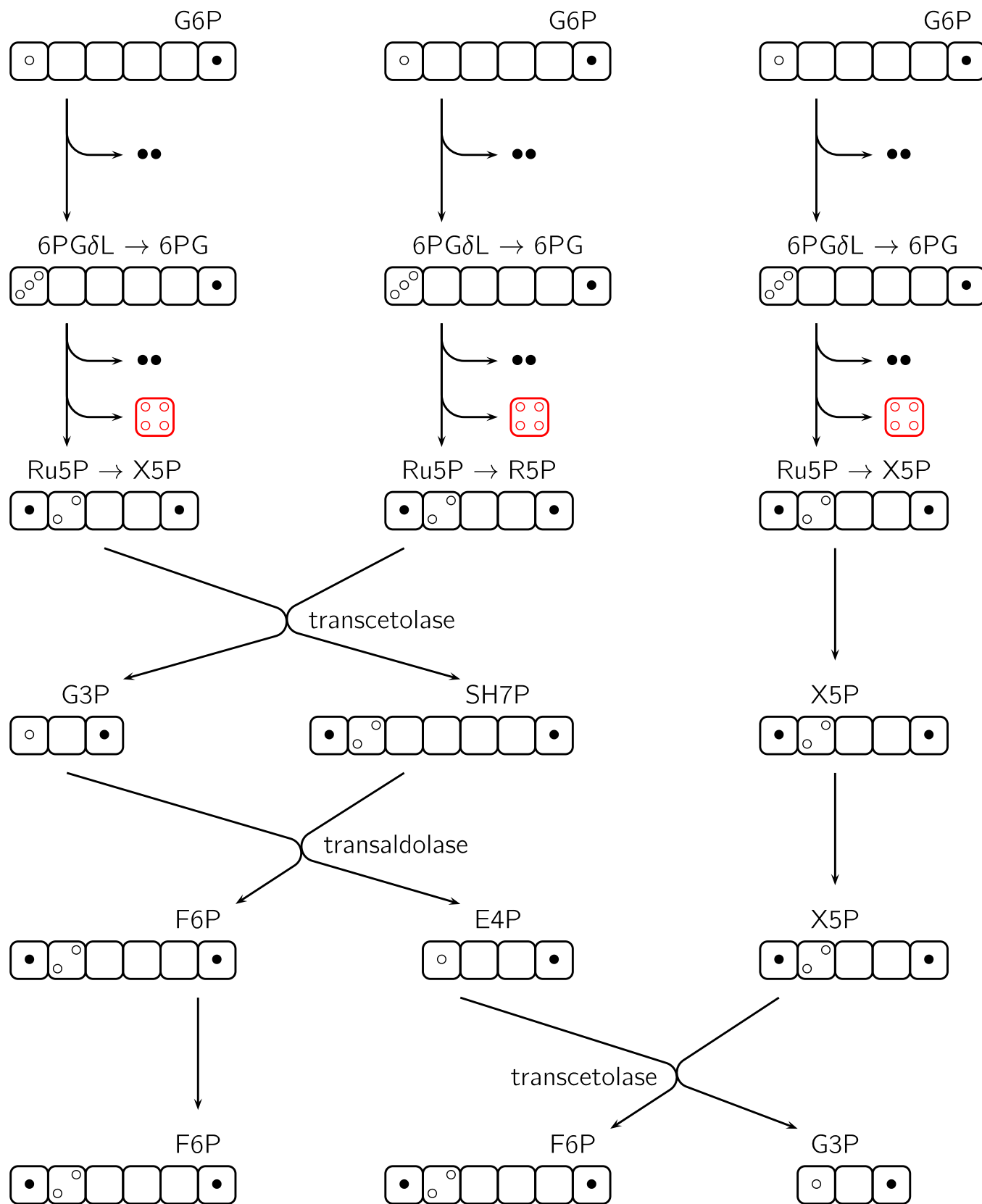

Fig. 8. The pentose-phosphate pathway can be decomposed in two oxidative steps, from G6P to Ru5P and X5P, followed by three non-oxidative steps, to F6P and G3P. Legend: G6P = Glucose-6-phosphate, 6PG δ L = 6-Phosphoglucono- δ -lactone, 6PG = 6-Phosphogluconate, Ru5P = D-Ribulose-5-phosphate, X5P = Xylulose-5-phosphate, R5P = D-Ribose-5-phosphate, G3P = D-Glyceraldehyde-3-phosphate, SH7P = D-Sedoheptulose-7-phosphate, F6P = D-Fructose-6-phosphate, E4P = D-Erythrose-5-phosphate.

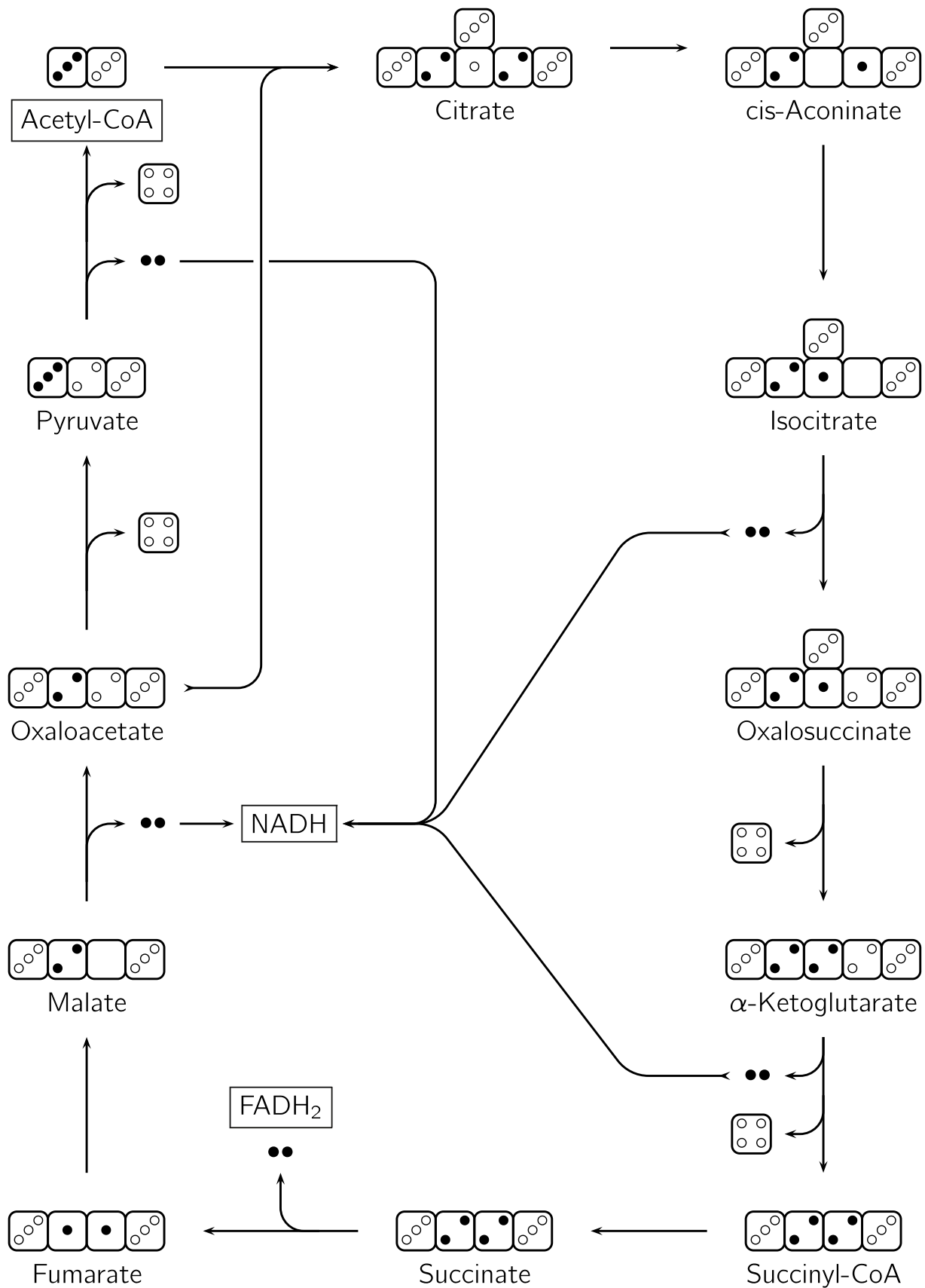

Fig. 9. In catabolic mode, the TCA cycle pumps electrons into the NADH and FADH₂ pools and carbon is fully oxidized into CO₂.

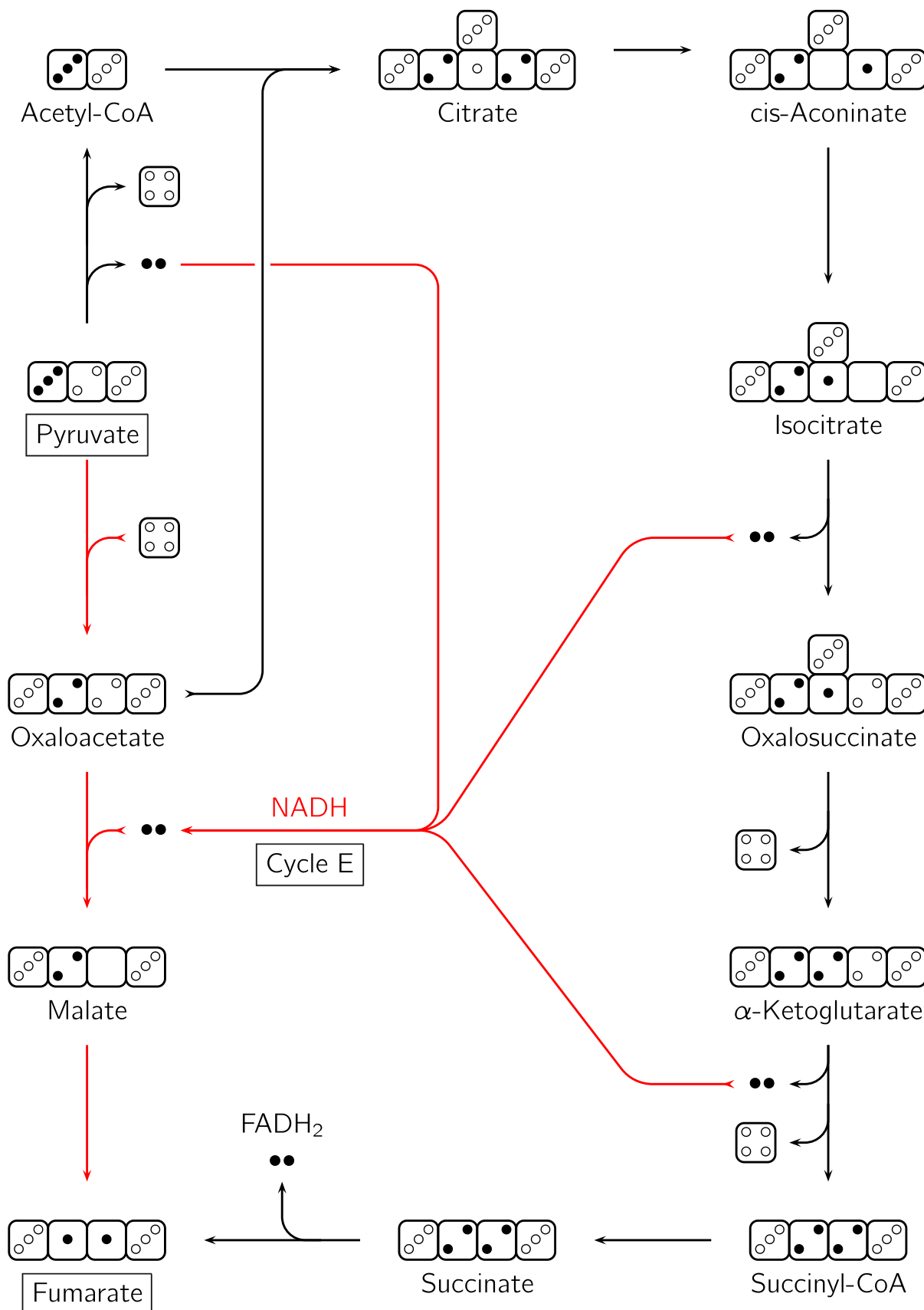

Fig. 10. In a reducing environment, the TCA cycle can be partially reversed: the pyruvate → fumarate branch is described backward with respect to the fully oxidative (clockwise) TCA cycle. Cycle E denotes the NAD shuttle between the oxidative and reductive branches.

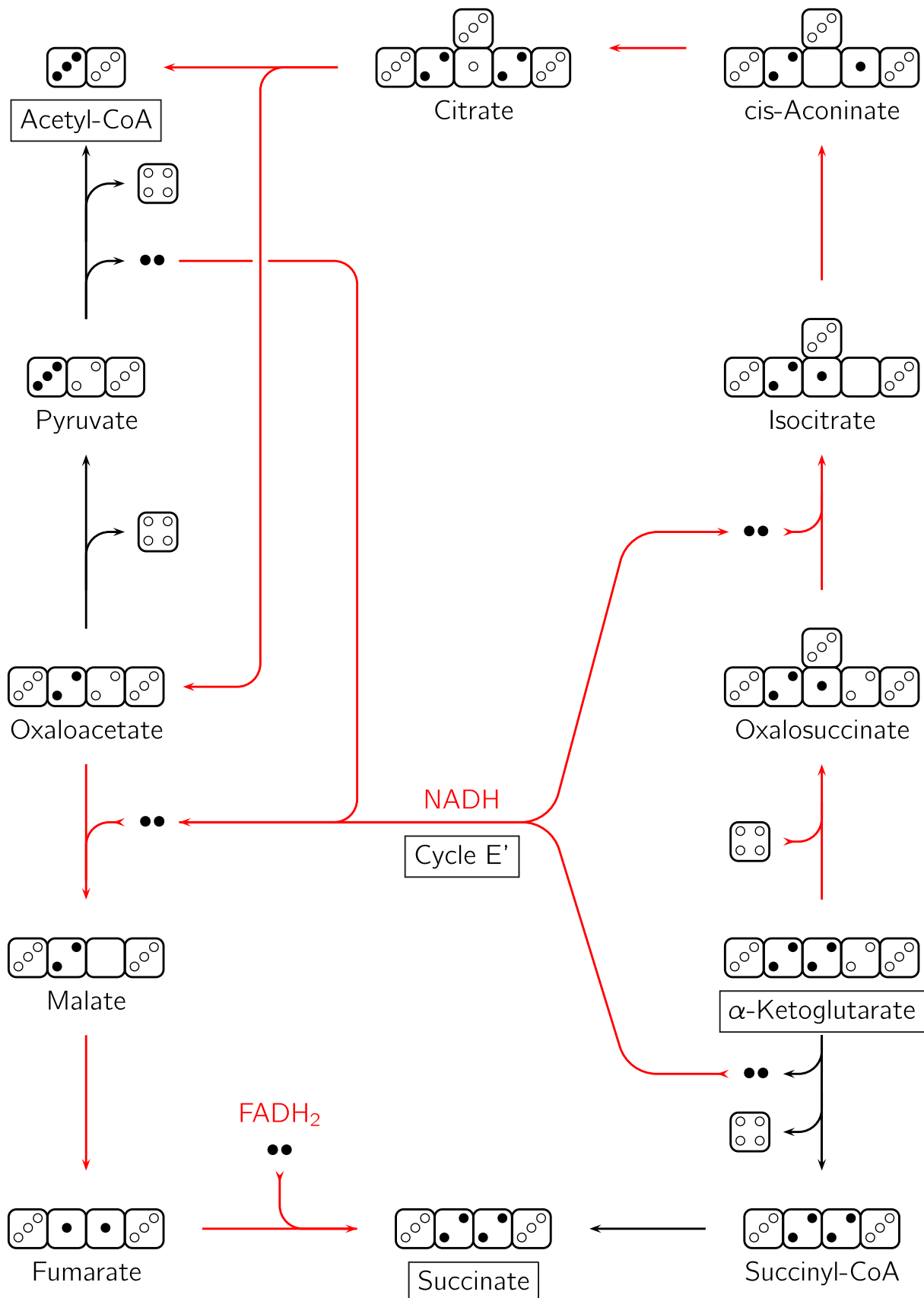

Fig. 11. In some cancer cells, a high influx of glutamine feeds the TCA cycle in α -ketoglutarate. A part of the latter is decarboxylated and oxidized into succinate while the other part is carboxylated and hydrogenated to form isocitrate. Acetyl-CoA and succinate are the end products of this partially reversed TCA cycle. Cycle E' denotes the NAD shuttle between the oxidative and reductive branches.

feeds the pools of precursors of amino-acids necessary to build proteins and clogs the route of electrons to oxygen. Moreover, when the acetyl-CoA pool is replenished by the reduction of α KG, the electrons flow uphill toward fatty acid synthesis with the help of NADPH.

Lack of oxygen at the level of complex IV increases the electronic pressure through a higher concentration of NADH. This forces the transfer of electrons from excess NADH to NADPH. An increased concentration of NADPH favors fatty acid synthesis with formation of NADP⁺. The excess NADP⁺ is reduced into NADPH by forming R5P in the pentose-phosphate pathway, refilling the NADPH pool, which fuels fatty acid synthesis. This positive feedback loop (**Cycle B** in Fig. 3) is, of course, a central hallmark of cancer: uncontrolled proliferation of cells with damaged DNA due to ROS, in parallel with a massive oxidative stress induced by the redox shift.

4.9. Metabolism as a bistable electric network

Animal cells result from the symbiosis of a cytoplasm and mitochondria that occurred about two billion years ago [55,56]. This duality is the origin of a metabolic bistability, where the electrons can flow either toward oxygen through mitochondria or toward biomass formation in the cytoplasm. In quiescent cells, the mitochondria take over the cytoplasm by channeling the electrons to the respiratory chain, but as soon as this electric conduction is impaired, the proliferative phenotype of the anaerobic cytoplasm changes the cellular behaviour.

This dissipative electric network stores part of the incoming energy flow in high energy phosphate bonds (P^{*}), in reduced coenzymes and in C - C bonds of biomolecules. In a steady state, the electrons follow the path of highest probability and chemical reactions of extremal entropy production [57]. As a function of the electron current, J , from acetate to fatty acids the rate of entropy formation, $\Phi(J)$, must have two minima: one for $J = J_+^* > 0$ when fatty acid catabolism (β -oxidation) dominates biosynthesis, and another one for $J = J_-^* < 0$ when anabolism dominates catabolism. Such a situation, with two stable extrema, is observed in non-linear electric networks containing tunnel diodes [58] and many systems that undergo a saddle-node transition [59]. Therefore, we conjecture that the metabolism of animal cells can be represented by an electric network with a similar bistability phenomenon. When the asymmetry of the curve $\Phi(J)$ is too strong, a minimum fuses with the neighbour maximum and only one minimum remains, with $J^* < 0$ corresponding to a strongly glycolytic metabolism (Fig. 4C).

5. Redox sensitivity of the mTOR signaling pathway

Because of this bistability, cancer cells lean progressively toward uncontrolled anabolism. Indeed, the redox shift implied by the insufficient conductance of the mitochondrial network favors the synthesis of all the molecular building blocks of a new cell, but it is also necessary to coordinate higher synthesis processes in order to make a complete daughter cell from these molecules. An obvious candidate for the biological switch between two steady metabolic states glycolysis and respiration (OxPhos) is the mTOR system (mechanistic, or mammalian, Target Of Rapamycin) which is a central actor in the coordination of cell growth. In particular, its complex raptor-mTOR is sensitive to the concentration of nutrients.

Both embryonic stem cells and cancer cells appear to have activated mTOR signaling and both are energy fuelled essentially by cytoplasmic glycolysis, whereas the differentiated, non-dividing, working cells are fuelled by mitochondrial OxPhos. While mTOR is turned on, the speed and error rates in protein biosynthesis increase proportionally. Errors in the process of protein biosynthesis cause imperfect folding which sensitizes misfolded protein to oxidative damage (e.g., the irreversible carbonylation) leading to misfunction and/or toxic function by small pore-like aggregates. Indeed, both increase in chaperone levels and aggregate accumulation are among the hallmarks of cancer. Presumably

to protect the proteome from excessive oxidation, normal yeast cells use the TOR system to turn-off mitochondrial OxPhos when proteins are misfolded. Now, since cancer cells display a several-fold increase in protein carbonylation (compared to nearby healthy cells), whereas embryonic stem cells display the lowest measured levels of protein carbonylation [60], either ROS production is reduced in embryonic stem cells or the fidelity of protein biosynthesis is improved. This point merits experimental test. According to [61], *thiol oxidants induce activation of the raptor-mTOR pathway that correlates with a destabilization of the raptor-mTOR interaction, whereas a reducing reagent inhibits the pathway, and this correlates with a stabilization of the interaction.* Consequently, it seems that the triggers of mTOR in cancer cells are the reactive oxygen species rather than the excess reduced cofactors.

6. Methylene blue, O₂ consumption and ATP turnover

Several researches suggest that even if mitochondria work properly in some cancer cells there is an increased demand for NAD⁺ and the Warburg effect is a signature of this overload [38,62,63]. This observation points to the need for agents which can accept electrons from NADH or FADH₂ and relieve this overload, such as chlorine dioxide or methylene blue (MeB). The effects of methylene blue on cellular respiration have been observed for a long time. We propose here a simple electronic interpretation of its mode of action. Being an acceptor/donor molecule [64] MeB can act as an electronic bridge in parallel with the mitochondrial electron transport chain.

6.1. Oxygen consumption

Spontaneous oxidation of MeBH in presence of oxygen is fast. This explains the blue bottle experiment in which non-enzymatic oxidation of glucose with reduction of MeB into MeBH takes place. However, MeB remains in oxidized form (blue) because it is quickly reoxidized by molecular oxygen. If the reaction mixture is not subject to shaking, oxygen becomes exhausted with time, MeBH accumulates and the solution becomes colorless. Vigorous shaking restores oxygen levels and the blue color. The reoxidation reaction is:

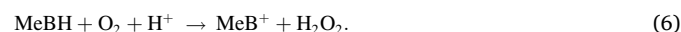

Within cells MeBH could act as an electron donor to the mitochondrial cytochrome-c. The reduced cytochrome-c is the substrate for the respiratory enzyme cytochrome oxidase with consumption of oxygen and generation of water, with lower oxygen consumption and without production of the oxygen reactive species H₂O₂:

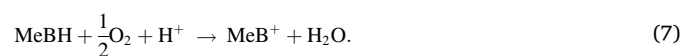

Cytochrom-c oxidation takes place as usual. Proton pumping occurs and contributes to the proton gradient used by ATP synthase to phosphorylate ADP into ATP. When cellular (or animal) oxygen consumption is stimulated by MeB both reactions 6 and 7 are conceivable. However, MeB is an antidote to cyanide which is a poison of cytochrome oxidase necessary for reaction 7. Moreover, the oxygen consumption of mammalian cells in presence of MeB remains fast and almost unchanged when cells have been poisoned by cyanide or with cells genetically deficient in cytochrome oxidase [65]. Therefore, although other, yet unknown reaction schemes may contribute to MeBH reoxidation, it is likely that reaction 7 could ensure fast reoxidation of MeBH within cells and outside. Release of H₂O₂ cannot constitute a criterion to quantitate contribution of reaction 7. Nor does it constitute a serious threat for a massive oxidative stress, because most cells are rich in catalase [66] that consumes H₂O₂ through the reaction:



The sum of reactions 6 and 8 equals reaction 7, so that on the ground of oxygen consumption these two pathways for MeBH reoxidation cannot be distinguished. Reaction 7 is the oxygen consumption step during normal oxidative metabolism of substrates like glucose or fatty acids. Notably, stimulation of oxygen consumption by MeB in an animal does not alter the ratio between carbon dioxide release and oxygen consumption [65]. Therefore, MeB could simulate increase or appearance of mitochondrial respiration although no mitochondrial respiratory enzymes would be involved. For example, oxygen consumption of cells genetically deficient in mitochondrial respiratory enzymes shows a great amplification by MeB with a maximal rate comparable to cells with normal mitochondrial respiration [65].

6.2. Oxidative metabolism

The cellular oxidation of glucose with modifications brought by different schemes of MeB reduction/oxidation pathways are considered (Fig. 5). Reoxidation schemes have been described above. With regard to reduction contribution of enzymes while any NAD or FAD using enzyme is a candidate for MeB reduction, the mitochondrial complex I deserves specific consideration because transfer of electrons from NADH to MeB by this enzyme is associated to proton pumping hence contributes to ATP formation. The MeB reduction/oxidation cycle also takes place and with equal intensity in cells genetically deficient in respiratory complexes [65] hence without contribution of mitochondria (Fig. 5c). Intermediate situations are examined (Table 3) with different consequences on ATP formation and sensitivity to mitochondrial inhibition. Maximal observed stimulation of oxygen consumption of the basal metabolic rate is approximately multiplied by three. This would be more than enough to restore a normal ATP turnover with all schemes involving mitochondrial contribution (Table 3). Because substrate linked ATP formation steps of metabolism are not affected by the yield (actually coupled state) of oxidative phosphorylation, the efficiency of metabolism stimulation increases as coupling decreases. In the example presented (Fig. 3) a $\times 3$ increase for the reaction scheme in absence of mitochondrial oxidative phosphorylation (Fig. 5c) would restore between $(3 \times 4)/34 \approx 35\%$ and $(3 \times 4)/20 = 60\%$ of the original ATP turnover rate.

6.3. Hydrogen peroxide issue

When the cyanide resistant schemes (Table 3) are considered H_2O_2 release becomes intense because it is linearly linked to metabolic rate. Several factors should then be considered to explain why cells and organisms could accommodate with high flux of H_2O_2 :

(1) As mentioned before, the high activity and affinity of catalase present in many cell types could explain cellular tolerance to this oxidant [66].

(2) Because of the permeability of biological membranes to oxidized or reduced MeB, the MeBH reoxidation is likely to be faster in the extracellular medium and/or blood where oxygen concentration is

Table 3

ATP yield per glucose molecule and inhibitors of the mitochondrial respiratory chain, with and without MeB (ROT = rotenone, AMC = antimycin, CAT = catalase).

Scheme	MeB reduction					MeB oxidation		ATP/ GLU	Inhibitors
	Others	I	II	III	IV	Others			
A		+	+	+	+		20 - 34	ROT, AMC & CN ⁻	
MeB			+		+		16 - 28	CN ⁻	
CB	+				+		11 - 17	CN ⁻	
BC		+	+			+	9 - 15	Fully resistant	
MeB + CAT	+					+	4	Fully resistant	

higher. Therefore, H_2O_2 generation would occur remote from sensitive intracellular targets.

(3) H_2O_2 formation bypasses the generation of superoxide ion, $O_2^{\bullet -}$, a reactive oxygen species of extremely short lifetime in presence of cellular targets hence with highest potential of damages.

However, H_2O_2 generation might explain the antiparasitic effect of MeB if the target organism is deficient in antioxidant defenses and unable to cope with the H_2O_2 generation rate to which it is exposed. A major electron donor to MeB is glycolysis [65], which could therefore expose highly glycolytic cells to higher H_2O_2 generation.

In a fully functional mitochondrial respiratory chain, without MeB, metabolism of each glucose molecule releases 6 CO_2 and reduced coenzymes (10 NADH and 2 $FADH_2$). Their reoxidation by the mitochondrial respiratory chain complexes I-IV consumes 6 O_2 and generates 12 H_2O (rounded boxes enclose consumed molecules in Fig. 5).

Table 3 indicates the possible combinations between redox events as described in Fig. 5 with their consequences on the ATP formation per glucose molecule. The highest value of ATP/GLU corresponds to theoretical prediction with a 100% coupled oxidative phosphorylation. The lowest value is obtained if this coupling is lowered to 50%. The last column indicates the sensitivity to inhibitors of the mitochondrial respiratory chain rotenone (complex I), antimycin (complex III) and cyanide (complex IV). Electron transfer to MeB in complex I occurs before the site of inhibition by rotenone and is therefore insensitive to this inhibitor. It is assumed that MeB electron transfer accepts/feeds 100% of flux for complexes I, II and IV. If not, ATP yield would increase as well as the sensitivity to inhibitors.

7. Conclusion and perspectives

In this hypothesis article, we have adopted a nanoscopic point of view which suggests that the conductance along the electron transport chains and across the mitochondrial membrane plays an important role in the altered metabolism that can be observed in some cancer cells. This modification enhances the oxidative stress and elevates the cytoplasmic pH, two major causes of oxidative protein damage. In cancer cells, the electrons can follow two kinds of short-circuits: (1) the cytoplasmic short-circuits established between glycolysis or the pentose-phosphate pathway and fatty acid synthesis and (2) the mitochondrial short-circuits between an oxidative branch and a reductive branch of the TCA cycle. From this point of view, the main actors of cellular metabolism are the valence electrons provided by the carbon atoms of substrates and the cellular metabolism is modeled by an electronic network. In some domain of its parameters compatible with animal life this network is bistable, working either as an anabolic machine producing biopolymers (and possibly a daughter cell) or as a catabolic machine producing water and carbon dioxide. We suggest that this thermodynamical bistability is at the core of the Warburg effect. In this language, cancer can be described as an electronic disease. The different metabolic abnormalities and the existence of cancer cells with normal metabolism in some tumor ecosystems hides a simple principle: cancer diverts electrons away from oxygen to satisfy its anabolic needs. This electronic rewiring is characterized by cycles (shuttles) which transfer electrons from oxidative branches to reductive branches of the metabolic network. Hence, identifying and unplugging electronic bottlenecks is an essential task of oncology. Unless the bottleneck at the pyruvate end is opened by lipoic acid and unless electrons that were not received by oxygen are drained by acceptor/donor molecules (like methylene blue) cancer cells will survive and proliferate. Unless the glutamine fermentation pathway is strongly inhibited [43], cachexia will remain a fatal consequence of these mitochondrial short-circuits. The purpose of the present work is neither to find the cause of the Warburg effect nor to propose a cure. It is a proposal to change the scale of observation and think about cancer as a modification of a thermodynamical, electronic network. It is a theoretical attempt to fit within physical principles the characteristics of cancer cells.

Funding information

This research did not receive any specific grant from funding agencies in the public, commercial or not-for-profit sectors.

Declaration of Competing Interest

The authors declare that they have no known competing financial interests or personal relationships that could have appeared to influence the work reported in this paper.

Data availability

Data will be made available on request.

References

- [1] H.J. Morowitz, *Energy flow in biology*, Academic Press, New York, 1968.
- [2] H.J. Morowitz, E. Smith, *The origin and nature of life on Earth*, Cambridge University Press, Cambridge UK, 2016.
- [3] O. Warburg, K. Posener, E. Negelein, Über den Stoffwechsel der Carcinomzelle, *Biochem. Z.* 152 (1924) 309–344.
- [4] D. Hanahan, R.A. Weinberg, Hallmarks of cancer, *Cell* 100 (2000) 57–70.
- [5] D. Hanahan, R.A. Weinberg, Hallmarks of cancer : the next generation, *Cell* 144 (2011) 646–674.
- [6] D. Hanahan, Hallmarks of cancer : New dimensions, *Cancer Discov.* 12 (2022) 31–46, <https://doi.org/10.1158/2159-8290.CD-21-1059>.
- [7] R.A. Weinberg, *The biology of cancer*, 2nd, Garland Science, New York, 2014.
- [8] H. Takahashi, R. Kawabata-Iwakawa, S. Ita, I. Mito, H. Tada, K. Chikamatsu, Upregulated glycolysis correlates with tumor progression and immune invasion in head and neck squamous cell carcinoma, *Scientific Reports* 11 (1) (2021) 17789.
- [9] Y.E. Moreira-Franco, M.J. Alves, M. Uno, I.F. Moretti, M. Trombetta-Lima, S. de Siqueira Santos, Glutaminolysis dynamics during astrocytoma progression correlates with tumor aggressiveness, *Cancer & Metabolism* 9 (11) (2021) 1–15.
- [10] M. Martins-Pinto, P. Paumard, C. Bouchez, S. Ransac, S. Duvezin-Caubet, J.-P. Mazat, M. Rigoulet, A. Devin, The Warburg effect and mitochondrial oxidative phosphorylation : friends or foes ? *BBA Bioenergetics* 1864 (2023) 148931.
- [11] H. Pelicano, R.H. Xu, M. Du, L. Feng, R. Sasaki, J.S. Carew, P. Huang, Mitochondrial respiration defects in cancer cells cause activation of AKT survival pathway through a redox mediated mechanism, *J. Cell Biology* 175 (6) (2006) 913–923.
- [12] A. Gill, Succinate dehydrogenase (SDH)-deficient neoplasia, *Histopathology* 72 (1) (2018) 106–116, <https://doi.org/10.1111/his.13277>.
- [13] P.-L. Tseng, W.-H. Wu, T.-H. Hu, C.-W. Chen, H.-C. Cheng, C.-F. Li, W.-H. Tsai, H.-J. Tsai, M.-C. Hsieh, J.-H. Chuang, W.-T. Chang, Decreased succinate dehydrogenase B in human hepatocellular carcinoma accelerates tumor malignancy by inducing the Warburg effect, *Nature Scientific Reports* 25 (8) (2018) 3081–3096, <https://doi.org/10.1038/s41598-018-21361-6>.
- [14] A. Casas-Benito, S. Martínez-Herrero, A. Martínez, Succinate-directed approaches for Warburg effect-targeted cancer management, an alternative to current treatments ? *Cancers* 15 (2023) 2862–2887, <https://doi.org/10.3390/cancers15102862>.
- [15] R. Braakman, E. Smith, The compositional and evolutionary logic of metabolism, *Physical Biology* 10 (2013), <https://doi.org/10.1088/1478-3975/10/1/011001>.
- [16] A.R. Mullen, W.W. Wheaton, E.S. Jin, P.-H. Chen, L.B. Sullivan, T. Cheng, Y. Yang, W.M. Linehan, N.S. Chandel, R.J. DeBernardinis, Reductive carboxylation supports growth in tumour cells with defective mitochondria, *Nature* 481 (2012) 385–388, <https://doi.org/10.1038/nature10642>.
- [17] F.V. Filipp, D.A. Scott, Z.A. Ronai, A.L. Osterman, J.W. Smith, Reverse TCA cycle flux through isocitrate dehydrogenases 1 and 2 is required for lipogenesis in hypoxic melanoma cells, *Pigment cell & melanoma Research* 25 (3) (2012) 375–383, <https://doi.org/10.1111/j.1755-148X.2011.00989.x>.
- [18] P.A. Gameiro, J. Yang, A.M. Metelo, R. Pérez-Carro, R. Baker, Z. Wang, A. Arreola, W.K. Rathmell, A. Olumi, P. López-Larrubia, G. Stephanopoulos, O. Iliopoulos, In vivo HIF-mediated reductive carboxylation is regulated by citrate levels and sensitizes VHL-deficient cells to glutamine deprivation, *Cell Metabolism* 17 (3) (2013) 372–385, <https://doi.org/10.1016/j.cmet.2013.02.002>.
- [19] D.J. Kerr, M. Baumann, *Oxford Textbook of Oncology*, Oxford University Press, Oxford, UK, 2016.
- [20] L. Giguère, R. Morais, On suppression of tumorigenicity in hybrid and cybrid mouse cells, *Somatic Cells Genetics* 7 (4) (1981) 457–471, <https://doi.org/10.1007/BF01542990>.
- [21] J.W. Shay, H. Werbin, Cytoplasmic suppression of tumorigenicity in reconstructed mouse cells, *Cancer Research* 48 (1988) 830–833.
- [22] C. Sonnenschein, A.M. Soto, The somatic mutation theory of cancer: growing problems with the paradigm ? *Bioessays* 26 (10) (2004) 1097–1107.
- [23] I. Prigogine, *Introduction to thermodynamics of irreversible processes*, John Wiley and Sons, New York, 1962.
- [24] A. Katchalsky, P.F. Curran, *Nonequilibrium Thermodynamics in Biophysics*, Harvard University Press, Cambridge, MA, 1965.
- [25] R. Bakalova, Z. Zhelev, I. Aoki, T. Saga, Tissue redox activity as a hallmark of carcinogenesis : from early to terminal stages of cancer, *Clinical Cancer Research* 19 (9) (2013) 2503–2517.
- [26] J.d.V. Moreira, M. Hamraz, M. Abolhassani, E. Bigan, S. Pérès, L. Paulevé, M. Levy-Nogueira, J.-M. Steyaert, L. Schwartz, The redox status of cancer cells supports mechanisms behind the Warburg effect, *Metabolites* 6 (4) (2016), <https://doi.org/10.3390/metabo6040033>.
- [27] A. Hoffman, L.M. Spetner, M. Burke, Ramifications of a redox switch within a normal cell: its absence in a cancer cell, *Free Radical Biology and Medicine* 45 (3) (2008) 265–268.
- [28] S. Cannito, E. Novo, A. Compagnone, L.V.d. Bonzo, L. Busletta, E. Zamara, M. Parola, Redox mechanisms switch on hypoxia-dependent epithelial-mesenchymal transition in cancer cells, *Carcinogenesis* 29 (12) (2008) 2267–2278.
- [29] A.K. Gombert, M.M. dos Santos, B. Christensen, J. Nielsen, Network identification and flux quantification in the central metabolism of *Saccharomyces cerevisiae* under different conditions of glucose repression, *J. Bacteriol.* 183 (4) (2001) 1441–1451, <https://doi.org/10.1128/JB.183.4.1441-1451.2001>.
- [30] J. Pouyssegur, A. Franchi, G. Lallemain, S. Paris, Cytoplasmic pH, a key determinant of growth factor-induced DNA synthesis in quiescent fibroblasts, *FEBS Letters* 190 (31) (1985) 115–119.
- [31] M. Morandi, E. Giannoni, E. Chiarugi, Nutrient exploitation within the tumorstroma metabolic crosstalk, *Trends in Cancer* 2 (12) (2016) 736–746.
- [32] L. Schwartz, T. Seyfried, K.O.A.J. DaVeiga-Moreira, S. Fais, Out of Warburg effect : an effective cancer treatment targeting the tumor specific metabolism and dysregulated pH, *Seminars in cancer biology* 43 (2017) 134–138.
- [33] H. Izumi, T. Torigoe, H. Isiguchi, H. Uramoto, Y. Yoshida, M. Tanabe, K. Khono, Cellular pH regulators: potentially promising molecular targets for cancer chemotherapy, *Cancer treatment reviews* 29 (6) (2003) 541–549.
- [34] S. Nandi, M. Razzaghi, D. Srivastava, M. Dey, Structural basis for allosteric regulation of pyruvate kinase M2 by phosphorylation and acetylation, *J. Biol. Chem.* 295 (51) (2020) 17425–17440.
- [35] Y. Lu, T. Pang, J. Wang, D. Xiong, L. Ma, B. Li, S. Wakabayashi, Down-regulation of p-glycoprotein expression by sustained intracellular acidification in K562/Dox cells, *Biochemical and biophysical research communications* 377 (2) (2008) 441–446.
- [36] M.F. McCarty, J. Whitaker, Manipulating tumor acidification as a cancer treatment strategy, *Altern. Med. Rev.* 15 (3) (2010) 264–272.
- [37] B.Y. Wang, J. Zhang, J.L. Wang, S. Sun, Z.H. Wang, L.P. Wang, X.C. Hu, Intermittent high dose proton pump inhibitor enhances the antitumor effects of chemotherapy in metastatic breast cancer, *J. Exp. & Clin. Cancer Res.* 34 (1) (2015) 1–12.
- [38] Y. Wang, E. Stancliffe, R. Fowle-Grider, R. Wang, C. Wang, M. Schwaiger-Haber, L. P. Shriver, G.J. Patti, Saturation of the mitochondrial NADH shuttles drives aerobic glycolysis in proliferating cells, *Molecular Cell* 82 (17) (2022) 3270–3283, <https://doi.org/10.1016/j.molcel.2022.07.007>.
- [39] L. Alberghina, D. Gaglio, Redox control of glutamine utilization in cancer, *Cell death and disease* 5 (12) (2014) e1561, <https://doi.org/10.1038/cddis.2014.513>.
- [40] M. Ying, D. You, X. Zhu, L. Cai, S. Zeng, X. Hu, Lactate and glutamine support NADPH generation in cancer cells under glucose-deprived conditions, *Redox biology* 46 (2021) 102065.
- [41] H.Q. Ju, J.F. Lin, T. Tian, D. Xie, R.H. Xu, NADPH homeostasis in cancer: functions, mechanisms and therapeutic implications, *Signal transduction and targeted therapy* 5 (1) (2020) 1–12.
- [42] E. Gaude, C. Schmidt, P.A. Gammage, A. Dugourd, T. Blacker, S.P. Chew, C. Frezza, NADH shuttling couples cytosolic reductive carboxylation of glutamine with glycolysis in cells with mitochondrial dysfunction, *Molecular cell* 69 (4) (2018) 581–593.
- [43] T.N. Seyfried, *Cancer as a metabolic disease*, John Wiley & Sons, Hoboken NJ, 2012.
- [44] J. Zhang, P.-P. Jia, Q.-L. Liu, M.-H. Cong, Y. Gao, H.-P. Shi, W.-N. Yu, M.-Y. Miao, Low ketolytic enzyme levels in tumors predict ketogenic diet responses in cancer cell lines in vitro and in vivo, *J. Lipid Research* 59 (2018) 625–634, <https://doi.org/10.1194/jlr.M082040>.
- [45] M. Israël, L. Schwartz, The metabolic rewiring observed in cancer renders tumor cells dependent of ketone bodies and vulnerable to SCOT inhibition, *Endocrinol., Diabetes and Metabol. J.* 4 (2020) 14.
- [46] M. Abolhassani, E. Berg, G. Tenenbaum, M. Israël, Inhibition of SCOT and ketolysis decreases tumor growth and inflammation in the Lewis cancer model, *Japanese J. Oncol. Clin. Res.* 3 (104) (2022) 1–12.
- [47] M.A. Kiebish, X. Han, H. Cheng, J.H. Chuang, T.N. Seyfried, Cardiolipin and electron transport chain abnormalities in mouse brain tumor mitochondria : lipidomic evidence supporting the Warburg theory of cancer, *J. Lipid Res.* 49 (2008) 2545–2556.
- [48] H.G. Crabtree, Observations on the carbohydrate metabolism of tumors, *Biochemical J.* 23 (3) (1929) 536.
- [49] H.J. Morowitz, E. Smith, Universality in intermediate metabolism, *Proc. Nat. Acad. Sci. USA* 101(36) (36) (2004) 13168–13173, <https://doi.org/10.1073/pnas.0404922101>.
- [50] L.J. Sweetlove, K.F.M. Beard, A. Nunes-Nesi, A.R. Fernie, R.G. Ratcliffe, Not just a circle: flux modes in the plant TCA cycle, *Trends in Plant Science* 15 (2010) 462–470, <https://doi.org/10.1016/j.tplants.2010.05.006>.
- [51] B.B. Buchanan, R. Sirevag, G. Fuchs, R.N. Ivanovsky, Y. Igarashi, M. Ishii, F. R. Tabita, I.A. Berg, The Arnon-Buchanan cycle : a retrospective, 1966–2016, *Photosynthesis Research* 134 (2017) 117–131.
- [52] N. Lane, *Transformer*, Profile Books, London, 2022.

- [53] D.R. Wise, J.E. Shay, J.R. Cross, J.J. Gruber, U.M. Sachdeva, Hypoxia promotes isocitrate dehydrogenase-dependent carboxylation of α -ketoglutarate to citrate to support cell growth and viability, *Proc. Nat. Acad. Sci. USA* 108 (49) (2011) 19611–19616, <https://doi.org/10.1073/pnas.1117773108>.
- [54] A.R. Mullen, Z. Hu, X. Shi, L. Jiang, L.K. Boroughs, Z. Kovacs, R. Boriack, D. Rakheja, L.B. Sullivan, W.M. Linehan, N.S. Chandel, R.J. DeBernardinis, Oxidation of alpha-ketoglutarate is required for reductive carboxylation in cancer cells with mitochondrial defects, *Cell Reports* 7 (2014) 1679–1690.
- [55] B.M. Kozo-Polyansky, *Symbiogenesis : A new principle of evolution*, Harvard University Press, 2010.
- [56] L. Margulis, *Origin of eukaryotic cells*, Yale University Press, 1970.
- [57] P. Glansdorff, I. Prigogine, *Thermodynamic theory of structure, stability and fluctuations*, Wiley Interscience, New York, 1971.
- [58] J.K. Moser, Bistable systems of differential equations with applications to tunnel diode circuits, *IBM Journal* (1961) 226–240.
- [59] S.H. Strogatz, *Nonlinear Dynamics and Chaos*, 2nd, Westview Press, New York, 1994.
- [60] A. Krisko, M. Radman, Protein damage, ageing and age-related diseases, *Open Biol.* 9 (2019) 180249, <https://doi.org/10.1098/rsob.180249>.
- [61] D.D. Sabrassov, D.M. Sabatini, Redox regulation of the nutrient-sensitive Raptor-mTOR pathway and complex, *Journal of Biological Chemistry* 280 (47) (2005) 39505–39509.
- [62] A. Luengo, Z. Li, D.Y. Gui, L.B. Sullivan, M. Zagorulya, B.T. Do, M.G.V. Heiden, Increased demand for NAD⁺ relative to ATP drives aerobic glycolysis, *Molecular Cell* 81 (4) (2021) 691–707.
- [63] Y. Wang, G.J. Patti, The Warburg effect : a signature of mitochondrial overload, *Trends in Cell Biology* (2023), <https://doi.org/10.1016/j.tcb.2023.03.013>.
- [64] A. Pullman, B. Pullman, *Quantum Biochemistry*, Interscience Publishers, New York, 1963.
- [65] F. Bouillaud, C. Ransy, M. Moreau, J. Benhaim, A. Lombès, P. Haouzi, Methylene blue-induced O₂ consumption is not dependent on mitochondrial oxidative phosphorylation : Implications for salvage pathways during acute mitochondrial poisoning, *Respiratory Physiology & Neurobiology* 304 (2022) 103939, <https://doi.org/10.1016/j.resp.2022.103939>.
- [66] C. Ransy, C. Vaz, A. Lombès, F. Bouillaud, Use of H₂O₂ to Cause Oxidative Stress, the Catalase Issue, *Int. J. Mol. Sci.* 21 (23) (2020), <https://doi.org/10.3390/ijms21239149>.